



carbon neutral 2030

Streetspace Carbon Neutral 2030 puts climate commitment at the forefront of group business strategy. Working to a sequence of measures we are progressing towards a sustainable future with Euro 6 and electric vehicle fleet, reduced commercial travel, increased use of renewables for heat and power generation in our offices and factories together with responsible sourcing throughout our supply chain for sustainable employment, energy use, waste and shipping.

Recognising that an external structure is a perfect opportunity for fitting a green roof and supporting our ecosystem, Streetspace developed its first green roof bin store in 2009. This commitment to developing products that are designed with the environment in mind is demonstrated in the fact that most products are available with an extensive sedum roof, and selected models available with the intensive system boasting wildflowers.

Streetspace Ltd has an Environmental Management System that complies with ISO 14001:2015. Since 2017 the following are some of the measures that have been put in place as continuous improvement:

- High efficiency lighting has been installed in our factory buildings and offices.
- Offices are heated and cooled using air-source heat pumps.
- All non-production steel is 100% recycled and separated at source from fabrication and sheet metal processes.
- All timber cladding products are sustainably sourced and certified with non-production material separated at source for 100% recycling.
- Reusable steel stillages are used for handling and delivery of urbanspec, Streetspace and metroSTOR products to site minimise pallet usage and packaging waste.

The next steps in our ongoing commitment to reducing carbon footprint ahead of Streetspace Carbon Neutral 2030 include the investment in further integrated factory production processes with the objective of saving thousands of miles transporting sub-assemblies between coating sites.

welcome

urbanspec is the external works brand from Streetspace, with an integrated design and engineering methodology that delivers class leading product systems for bike parking, bin stores, canopies and street furniture.

Easing the journey through specification, design and engineering, to manufacture, installation and aftercare, urbanspec product systems reduce design time, de-risk specifications and remove hassle on site for architects and contractors alike.

A unique series of pre-engineered design layouts, configurable for function, capacity, features and finishes provide the foundation for our cost-effective product systems. urbanspec integrated design and engineering methodology builds on this for custom manufacturing, tailored to site-specific requirements without the cost and complexity of traditional processes. Working with a proven design platform means the addition of specific product features to satisfy planning design requirements in the urban landscape such as biodiverse green roof structures, or approved security rated builds, can be accommodated with ease.



contents

- 06. about
- 08. urbanspec resources
- 10. sectors
- 26. green roof for external storage buildings
- 30. 3d bin & cycle store configurator
- 32. bike stores, shelters & racks
- 60. bin stores, screens & enclosures
- 80. external stores & lockers
- 90. street furniture
- 102. canopy structures
- 116. urbanspec specifier process
- 118. our brands



urbanspec

about

Coordinated design elements enable realistic single source procurement for the complete external works project scope. Our own factories and distribution systems enable short lead-times with many product configurations from stock components. Online specification and buying is available for fast moving products.

Developed over years of experience, the urbanspec knowledge base provides valuable design and specification information for each stage of the project journey. From CPD training programmes, best practice and statutory guidance advice to detailed cost information including value engineering assessments. Space planning services optimise product solutions to provide the required capacity within the constraints of footprint and budget.

urbanspec products are UK manufactured in accordance with BS EN 1090, ISO 9001:2015 and ISO 14001:2015 accredited processes, providing proven engineering design and reliability backed with a 5 year warranty. With the capability to deliver end to end complex project installations, our qualified and experienced Project Managers operate across the UK. Post installation, our comprehensive product support with proven and reliable product systems is backed by Streetspace parts inventory stock and nationwide Site Engineers.

Sustainability is at the heart of Streetspace Group ethos, with our product design and specification processes structured to maximise end-of-life recyclable value and the use of sustainably sourced materials throughout manufacture and installation.

urbanspec resources

Our goal is to make it simple and straightforward for you to select the right solution for your specific requirements and to save you time designing bespoke structures unnecessarily. urbanspec products are designed for ease of project inclusion, and are easily configurable, with custom designs available to fit your development perfectly.

We are continually developing our range of easy-to-use free resources to assist you, and our technical team is on hand to answer any queries you may have – we always welcome the opportunity to discuss projects you are working on.



NBS Source



bit.ly/spec-nbs

NBS Source is a free-to-use construction product platform that allows you to quickly and easily find, select and specify our products. Boasting enhanced product data in NBS standardised specification format and a range of content, from case studies to third party certificates; NBS Source gives you the detailed information you need to make informed product decisions.

Datasheets

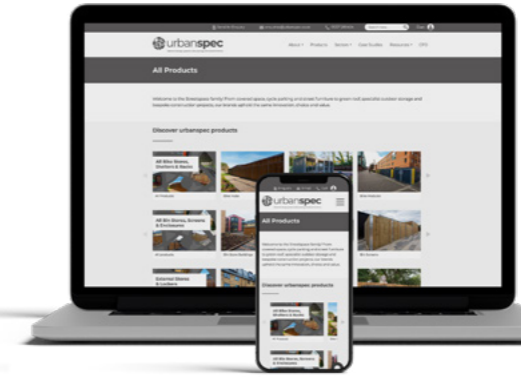

bit.ly/spec-products

urbanspec datasheets are available to download, detailing product information including locking, finish, aperture and signage options.

Design Information

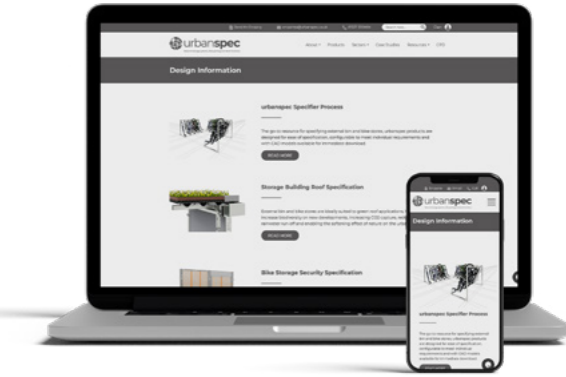

bit.ly/spec-design-info

Read more about our specifier process, greenroof specification and storage specification.

commercial

sector

urbanspec offers a wide variety of external works solutions well-suited for use in a range of new-build commercial settings, from science and business parks to retail centres and industrial estates. With speculative developments aiming to attract businesses through a combination of innovative design, effective space planning and placing a focus on creating sustainable and biodiverse environments, urbanspec products provide customisable bespoke options that encourage striking first impressions.

urbanspec's extensive range of pre-engineered storage products are configurable to meet specific project design requirements, easing the specification process and saving time on design planning with a supporting database of accurate technical data and CAD models available for download.

Our range of storage products are factory manufactured with a 5 year warranty ensuring the durability required in commercial settings and ready availability of product lines. urbanspec products can be configured to meet site specific space planning requirements as well as offering compliance with stipulated planning conditions. Security needs are addressed with a variety of available access control systems, restricting use to site-specific users. A range of urbanspec storage units can be ordered in Secured by Design specifications, accredited by Sold Secure.



Case Studies - Commercial: St Modwen Park, Newport

Client: St. Modwen Logistics

Architect: Roberts Limbrick

Main Contractor: Benniman Ltd

Scope: BIKE-S Bike Module, urbanspec E-Series Bin Screen Systems

St. Modwen Park in Newport is a sought after industrial and logistics hub strategically located at the gateway to South Wales. Close proximity to Junction 23a and the M4 provide excellent transport links to both Wales and the Southwest with Cardiff located only 12 miles away and Bristol 30 miles. Close proximity to the Swansea to Paddington Mainline and the proposed Llanwern Park & Ride Metro Railway station provide ideal commuting links into the park. The park has already successfully attracted well known organisations such as Amazon and CAF's £50m train production facility.

As part of the ambitious development plan by St Modwen Logistics & Industrial, top specification office space, generous parking and yard facilities were designed to help attract further manufacturing and distribution businesses to the park. The

second phase of this scheme included the development of 130,000 sq ft of warehousing & industrial space in addition to the 215,000 sq ft of space already completed.

Adding secure cycle storage was a requirement as part of the ongoing development scheme. Main contractor Benniman Ltd specified 3no. BIKE-S 12 units with integral bike racks and locking points providing secure storage for 36 bikes. Each store was designed to occupy a 2002mm x 4818mm footprint.

The BIKE-S units were specified with urbanspec Firenze Anthracite heavy gauge steel panels and HD galvanised frame for excellent long term durability. For a consistent design approach each unit featured vertical signage with colour scheme specific to the St Modwen development complimenting the surrounding architecture. The open fronted design and unique slot pattern in the panels provides clear line of site through the store for personal security.

urbanspec E-Series Bin Screen Systems and bespoke urbanspec E-Series Screen Systems for fixed plant and recycling bins were included in the external works supply and fit package. These also used the same colour scheme for design consistency.



residential

sector

Providing products for external works packages across new-build and residential developments, urbanspec supplies internal and external bin and bike stores that maximise the usage of space in high density residential environments, which is often at a premium.

urbanspec's extensive resource and knowledge base makes the specification process easy, with CAD models, NBS specifications and datasheets available for download to facilitate the design and planning process. Supporting CPD programmes provide clarity on the best available practices for space planning, fire guidance and security considerations.

Our proven design platform offers a comprehensive range of pre-engineered design layouts configurable to meet individual project requirements in residential settings. A variety of options for cladding and finishes are available, enabling coordination with the architectural design elements of a development.

Security and cycle theft prevention are addressed with a range of urbanspec products available to order in Secured by Design specification, accredited by Sold Secure. A variety of access control systems, ranging from app-based smartphone systems to fob operated user access, enable residents to use our products with confidence.

With specifications available for green roof systems, urbanspec bin and bike stores provide an ideal platform for encouraging biodiversity on a development. Our products can be incorporated into planning applications and ecological impact assessments in order to achieve BNG targets, in addition to performance requirements for BREEAM certification. Green roofs can be specified as either extensive or intensive lightweight systems to suit preference.



Case Studies - Residential: The Cocoa Works, York City Centre

Architect: Weedon Architects

Main Contractor: Henry Boot Construction

Scope: H-Series Bike Hub

As part of the development of its exterior space, urbanspec provided bespoke H-Series Bike Hubs for this large renovation project. Specified by Weedon Architects collaborating with Henry Boot Construction, they feature a mix of timber panel cladding and Z-Panel V-Mesh security finishes. It's one of the most configurable design platforms for outdoor storage in the world, with over 120 pre-engineered build layouts.

Situated just an eight minute walk from York City Centre, The Cocoa Works boasts an exciting mix of historic features and contemporary design. Originally built in the early 1890s by Joseph Rowntree, the site is of great historical significance to York. Housing the famous Rowntree confectionery factory, it was not just a place of work but also included a gym, school rooms and a lecture hall. Carefully renovated into 279 homes with landscaped gardens and communal spaces, new life is being breathed into this heritage building.



Check out our 3D Bin & Cycle Store Configurator

Quickly generate a 3D view of
your desired product in real time.

Learn more
on page **30**



education

sector

Benefiting educational environments from primary school level to higher education, urbanspec provides products for external works packages for projects ranging from new builds to refurbishments and extensions. Addressing the specific challenges that arise in the sector, our range of external storage and covered space products can be used to optimise external spaces, providing opportunities to enhance the educational experience.

urbanspec products utilise designs that can be tailored to meet the needs of the education sector and individual requirements, in addition to offering design-coordinated product groups. Our proven ability to deliver bespoke projects is achieved by a consideration of varied site layouts and footprint restrictions, coupled with our single-source solution that negates the requirement for numerous sub contractors to attend on-site premises.

Catering for a range of learning environments and student populations, urbanspec provides access control options to suit multiple users. In higher-education settings, these can be specified for site-specific users utilising app-based smartphone and fob-operated systems in order to create a uniformed mode of access.

The availability of options for cladding and finish varieties allows for seamless coordination with the architectural design elements of a development. In addition, urbanspec external works products can be specified with green roof systems that are often integral to design, providing biodiverse elements to the architectural landscape.



Case Studies - Education: Queen Mary University London, Mile End Campus

Client: Queen Mary University London

Architect: BDP

Main Contractor: Beardwell Construction

Scope: urbanspec BIKE-S Bike Module

As a Russel Group Institution, Queen Mary is recognised as one of the UK's leading research-focused higher education institutions; teaching and researching across a wide range of subjects including medicine, dentistry, law, science & engineering. Based in East London and with over 31,000 students and 4500 staff the site in Mile End forms one of the largest residential higher education campuses in the capital.

Queen Mary University London are keen promoters of cycling as a healthy and sustainable travel option for students and staff moving between the five campuses and around the capital. The university has also recognised how cycling can help manage stress levels amongst students and staff, develop general physical health and serve as a quick and often budget friendly form of transport. On-site facilities have been developed over time to include shower and changing rooms, bike pump stations as well as secure storage lockers. The drive to get more people cycling

is also supported by an active university cycling group, bike maintenance and security sessions as well as a range of cycling events throughout the academic year. University staff are also able to take advantage of the Cycle to Work Scheme.

Looking to build on existing facilities, a study was undertaken by the University to assess existing cycle usage across university grounds and prepare for an anticipated uplift in cycle commuting as a result of the pandemic and a desire to move away from crowded public transport in the capital. The study revealed there was still a degree of adhoc cycle parking around key buildings even while student numbers were lower as a result of the pandemic. Following from the study a strategy was developed to create an improved cycle parking framework, providing secure, accessible and attractive parking facilities.

The strategy sought to deliver across a number of key areas, with significant focus on encouraging diverse and more inclusive populations to adopt cycling as a viable transport option, helping to reduce the issues caused by ad hoc parking. Relocating under-utilised cycle parking would help to ensure adequate facilities were available for those already cycling, with cycle theft reduced by providing secure storage for bikes.



Central to delivering an upgraded cycle parking framework for students and staff, was the investment in additional secure cycle parking across key locations. This was to be achieved through a range of short stay parking options as well as secure and enclosed parking units. As part of the ambitious development scheme, main contractor Beardwell Construction specified 16 BIKE-S Bike Modules, each securing 6 cycles. The units were installed in key locations across the university's sites, providing 96 additional secure cycle parking spaces.

Each of the 16 BIKE-S Bike Modules occupies a footprint of 2100mm x 2100mm and features Firenze Anthracite heavy gauge steel slotted vision panels to ensure a consistent line of sight and help aid personal security. Stepped locking trays are used to secure each bike and access control is provided by a locinox mechanical keypad, avoiding the need for users to carry keys. Vertical graphics panels are displayed on each unit and colour coordinated for different zones around the university campus.

healthcare

sector

With product groups designed to enable storage and covered space requirements, urbanspec provides a range of external works solutions for the healthcare sector. With hospital trusts and healthcare organisations often undertaking projects to introduce new treatment centres, care units or healthcare hubs, urbanspec products are designed to help develop on-site resources and create encouraging first impressions for on-site visitors.

urbanspec offers a wide range of canopy designs suitable for creating covered entrances and waiting areas for visitors to healthcare sites. urbanspec covered walkways are designed to provide much needed cover from the elements for staff and visitors as they transition between buildings on a site premises. Our product groups for the healthcare sector include storage solutions and bin screen systems for housing general waste and recycling, in addition to cycle storage and shelters. The urbanspec City3 Series of street furniture products also enables the creation of external seating areas for patients and staff, heightening architectural landscapes.

To suit project scale and individual requirements, our products can be tailored to suit both large hospital sites with multiple

buildings or projects with smaller footprints such as medical and GP practices, where effective space planning remains an integral consideration. With works usually undertaken while hospitals and treatment centres are in operation, product installations are organised in order to minimise disruption to crucial on-site functions and service delivery.

With a focus on providing functionality and design styles readily suited to healthcare settings, urbanspec storage products are available in a wide range of pre-engineered designs configurable to meet most project requirements and helping to facilitate short lead times. In addition, bespoke design options are available to meet specific project requirements. A variety of cladding and finishes allow for easy coordination with on-site architectural design elements, while options for green roof systems encourage biodiversity and help improve outdoor spaces.

Our extensive resource and knowledge base makes the specification process easy, with CAD models, NBS specifications and datasheets available for download to facilitate the design and planning process. Supporting CPD programmes provide clarity on the best available practices for space planning.



Case Studies - Healthcare: The Wilson Health Centre, Cheltenham

Client: Cheltmed

Main Contractor: B+K Building Services

Scope: Barrel Vault Tensile Canopy, 9m (L) x 5m (W)

Unveiled to the public in 2022, The Wilson Health Centre is a purpose-built, state-of-the-art surgery in Cheltenham, providing a new home to long established GP practices Berkeley Place, Royal Crescent and Prestbury Park. 40 NHS medical professionals are based at the surgery, including GP's, nurses, midwives, clinical pharmacists and health assistants, offering a diverse range of healthcare services to patients.

The Main Contractors for this new-build project were B+K Building Services, part of leading development group, Bowmer & Kirkland. urbanspec was specified by B+K to provide The Wilsons Health Centre with a bespoke external storage facility that could be utilised to provide multi-purpose storage capabilities.

The design flexibility of the urbanspec H-Series External Storage Building enabled urbanspec to meet the bespoke requirements of this project with a pre-engineered solution, utilising internal walls to divide the storage building's layout into 5 separate stores; all with individual external access and paired with respective signage to communicate intent.

Prioritising functionality, the urbanspec H-Series provides The Wilsons Health Centre with a specific store for dental waste in order to avoid contamination, a storage facility for liquid nitrogen canisters to ensure safety, as well as a store for both recyclable and general waste. The incorporation of a bike store into the design of the storage building provides staff with sheltered bike parking and secure storage for up to 12 individual bikes.

ForestPanel SW TGV cladding provides design coordination with timber cladding elements on the building façade. In order to enable constant ease of use for the surgery, in addition to restricting disruptions to patient services, the urbanspec H-Series was installed in an adjacent position to the building in the corner of the site's car park.



green roof for external storage buildings

For residential & commercial developments in the UK, integrating a green roof system to external storage can secure additional BREEAM or Sustainable Housing Code value, as well as being a valuable resource for achieving Biodiversity Net Gain (BNG) targets. BNG is the UK Government's sustainability strategy towards land developments that it hopes will provide an essential pathway towards ensuring the maintenance and recovery of nature and biodiversity in the UK. BNG aims to mitigate habitat losses by ensuring new developments give distinct consideration to the creation of essential new habitats, as well as enhancing those that already exist.

External storage systems are readily adaptable to support two types of green roof systems; sedum only and sedum and wildflower, ensuring BNG targets can be attained without the complexity of design and construction processes commonly associated with a bespoke build. Ideal for specification on bin stores, bike stores and storage units, their lower height from ground level and uncomplicated construction of these structures help to ensure original build and ongoing maintenance costs are reduced.

Specifying a green roof system on external storage provides a largely undisturbed space for plants and wildlife, significantly reducing water run-off, and reducing air pollution, while enabling valuable biodiversity to be introduced into urban environments. They help to provide a consistency of design, helping external stores reduce their visual impact to both blend in and soften the urban landscape. More general design considerations will cover aspects such as use, location and installation costs, however considering a number of technical design elements is necessary to ensure optimum output from a green roof system and meet criteria guidelines.



Sedum Roof

Maintenance

Weed when needed. Through dry/warm periods, water manually or by a watering system.

Wildflower Roof

Maintenance

1-2 cuts per year at the end of the flowering period and an optional cut in spring. Weed when needed. Through dry/warm periods, water manually or by a watering system.

Structural Design

Complying with all relevant structural design criteria, as per BS EN 1990:2002 Eurocodes. The loading guide for green roofs advises 65 kg/m² for a lightweight extensive sedum roof; 175 kg/m² for a biodiverse wildflower roof, and 250-400 kg/m² for an intensive roof.

Waterproofing

The primary waterproofing layer is critical to the performance of a green roof system. Its suitability must be assured by the BBA Certification process and needs to offer permanent protection by a membrane which prevents plant roots from growing through it.

Vegetation Type

A sedum mat is reliable and is able to be established quickly, while a wildflower mat offers a wider selection of species. Seed sowing tends to be a long and slow process but can enable a bespoke mix to be integrated. As an alternative, pre-cultivated plugs are a reliable bespoke method that are planted directly into the substrate growing medium, colonising the roof area to provide an even vegetative cover over time.

Substrate

Specifically designed to hold the optimum level of moisture, nutrients and air required for sustainable plant development, the growing medium typically contains a mix of organic and porous inorganic material.

Fire Resistance

As per BS EN 1990:2002 Eurocodes, green roofs should be designed to provide the necessary resistance to the external spread of fire. The substrate depth should be a minimum of 80mm, with a maximum 20% organic content. Fire breaks typically consist of non-vegetated strips and should be provided with a diameter of 30mm, or 50mm if using green roof pebbles.

Access and Maintenance

All green roofs require some degree of maintenance. Providing edge protection and a means of safe access by a roof anchorage system or containment system is strongly recommended, alongside a fall protection system to ensure safety for maintenance workers.

In relation to BNG, the biodiversity metric assesses the values of an ecosystem by considering the relative features of a specific habitat in order to calculate its biodiversity value. The metric can be asserted by a range of parties, and considers 5 key aspects: Type, Distinctiveness, Condition, Connectivity, and Size.

External storage systems can be designed to incorporate either extensive or intensive green roof systems. Alongside living walls and vegetated drainage systems, green roofs are currently the most effective solutions for delivering high levels of BNG on land developments, helping to highlight the need for sustainable solutions in urban environments.

storage building roof specification

urbanspec bin and bike stores are designed for ease of specification either pre-engineered or bespoke. The configurable approach extends to roof design systems where there are a number of factors to consider including site security requirements, planning conditions and biodiversity net gain considerations.

In standard configuration, urbanspec bin and bike stores have a profiled steel roofing system. An enclosure only specification is available where site conditions do not require a roof covering.

External bin and bike stores are ideally suited to green roof applications, helping increase biodiversity on new developments, increasing CO2 capture, reducing rainwater run-off and enabling the softening effect of nature on the urban landscape.

Specified with either extensive or intensive lightweight green roof systems, urbanspec H-Series extensive systems support primarily sedum plants, while the intensive version with an increased substrate depth, supports a mix of sedum and wildflower plants.

There are five urbanspec Roof Design Systems:

1. urbanspec H-Series Standard Steel Profiled Roof System
2. urbanspec H-Series Steel Profile / Fire Resistant (FR) Liner Roof System
3. urbanspec H-Series Green Roof System (Intensive)
4. urbanspec H-Series Green Roof System (Extensive)
5. urbanspec H-Series Enclosure Only Specification

1. urbanspec H-Series Standard Steel Profiled Roof System

- 1 Steel trapezoidal profile 32/1000mm sheet. Colour coat anthracite grey outer / white lower
- 2 Steel RHS rafter sections / HD Galvanised finish
- 3 Steel RHS eaves beam / HD Galvanised (optional colour powder coat) finish
- 4 Steel box profile gutter section / Galvanised (optional colour powder coat) finish



2. urbanspec H-Series Steel Profile / Fire Resistant (FR) Liner Roof System

- 1 Steel trapezoidal profile 32/1000mm sheet. Colour coat anthracite grey outer / white lower
- 2 Non-Combustible Fire Protection Board
- 3 Steel trapezoidal profile liner sheet
- 4 Steel RHS rafter sections / HD Galvanised finish
- 5 Steel RHS eaves beam / HD Galvanised (optional colour powder coat) finish
- 6 Steel box profile gutter section / Galvanised (optional colour powder coat) finish



3. urbanspec H-Series Green Roof System (Intensive)

- 1 Vegetation mat pre-planted sedum and wildflower mix
- 2 Green roof substrate blend of lightweight water retaining aggregates and composted organic material
- 3 Drainage Reservoir System double-sided to provide drainage and water retention made from recycled plastic
- 4 Root Membrane geotextile lining sheet preventing any damage to the waterproof liner during installation or establishment phase
- 5 Waterproof single sheet EPDM liner which is 100% synthetic and UV resistant
- 6 Green roof structural deck constructed from full-length trapezoidal profile steel sheet with double sided zinc and paint finish
- 7 Steel RHS eaves beam / Profiled steel fascia galvanised (optional colour powder coat) finish
- 8 Steel box profile gutter section galvanised (optional colour powder coat) finish

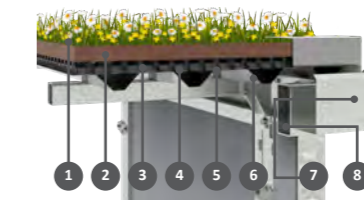

4. urbanspec H-Series Green Roof System (Extensive)

- 1 Vegetation mat pre-planted sedum mix
- 2 Green roof mineral wool based growing medium felt
- 3 Drainage Reservoir System double-sided to provide drainage and water retention made from recycled plastic
- 4 Root Membrane geotextile lining sheet preventing any damage to the waterproof liner during installation or establishment phase
- 5 Waterproof single sheet EPDM liner which is 100% synthetic and UV resistant
- 6 Green roof structural deck constructed from full-length trapezoidal profile steel sheet with double sided zinc and paint finish
- 7 Steel RHS eaves beam / Profiled steel fascia galvanised (optional colour powder coat) finish
- 8 Steel box profile gutter section galvanised (optional colour powder coat) finish

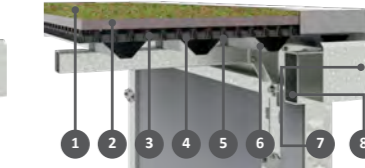

5. urbanspec H-Series Enclosure Only Specification

- 1 Steel RHS Column Sections / HD Galvanised
- 2 Steel box profile panel trim galvanised finish



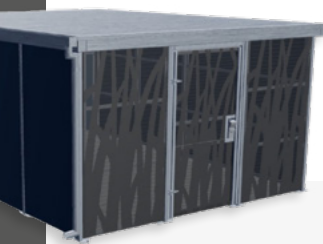

3D Bin & Cycle Store Configurator

Introducing our 3D Configurator tool. This tool will allow specifiers to quickly generate a 3D view of their desired product and configure it in real time. From size and capacity to wall structures, door placement and more, discovering the possibilities of our products is a breeze.



1 Storage Type

- To start, select the storage type you'd like to configure
- If choosing a cycle store, select your preferred type of racks: Bike Stands, Semi-Vertical Racks, or Two-Tier Racks. The total capacity of the store will vary based on the racks chosen
- Choose the size of the unit

2 Size and Capacity

- Once the storage type is selected, specify the desired size and capacity
- The configurator will then load the unit shell in the desired size



3 Wall Structure

- Select a wall number (1-4)
- Choose your preferred cladding: Timber, Toughened Glass, ZedPanel Mesh, or Steel
- Repeat for the other 3 walls



4 Wall Finish

- Select the wall finish / colour for each cladding type



5 Door Location

- Decide where to place the door. Doors are available on any wall, with up to three possible positions per wall
- Choose between a Eurocylinder lock or a Digital Code Lock



6 Roof

- Select either a Steel Roof or a Green Roof
- Once completed, download a PDF of your creation

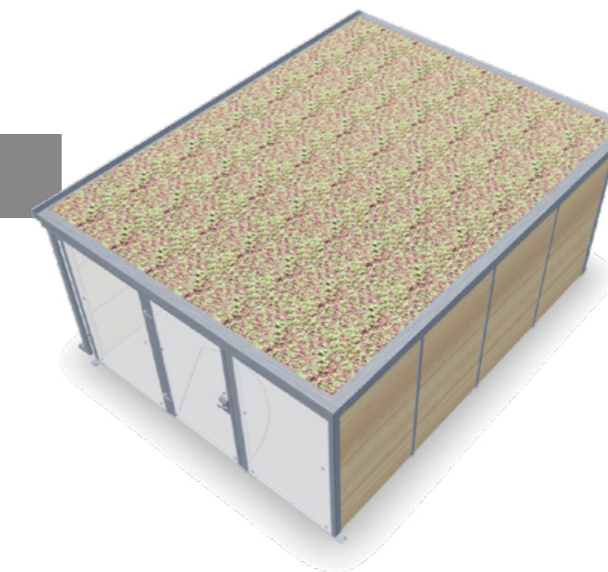

7

Scan or click to use our 3D configurator

Try it for yourself



bit.ly/spec-config

Bike stores, shelters & racks

urbanspec is one of the largest bike parking and external storage manufacturers in the UK and the urbanspec product line spans bike stands, racks, lockers, shelters, stores and hub buildings.

urbanspec is unique in the bike storage marketplace with an integrated design and engineering methodology that combines the efficiency of volume manufacture with custom build capability. These include green roof applications, with external bin and bike stores being ideally suited to provide a valuable component in achieving Biodiversity Net Gain targets for new developments.

urbanspec M-Series and H-Series design enables specifiers to select cladding and finishes with multiple options for customisation. This makes site wide design coordination and single source procurement a realistic concept for external works projects.

Advanced manufacturing of high volume bike shelters and bike rack products enable short lead times, capacity format variations and competitive pricing. Our bike shelters are produced in semi enclosed CL format, with single row CS and double row CLS both available in single level and two-tier rack formats. From vertical hanger to two-tier bike racks, all types are available from stock as standalone or pre-configured to maximise capacity in urbanspec stores and shelters.



The prevention of bike theft is a central to urbanspec product design and our H-Series Bike Hub Buildings, M-Series Bike Stores and Bike-S Modules can be ordered in Secure By Design specifications, accredited by Sold Secure. Our integrated design and engineering approach extends to access control options for bike stores and hubs, where key operated, mechanical keypad, smartphone access and fob operated locking systems can be accommodated within our proven steel door and frame design.

The London Cycling Design Standards (LCDS)

The London Cycling Design Standards (LCDS) sets out the requirements and guidance for designing cycle-friendly storage, spaces, and streets. For bike storage provision, the LCDS outlines key dimensional requirements to follow, including the use of Sheffield hoops and two-tier bike racks. Additionally, 5% of the total capacity should be allocated for larger bikes, with Sheffield hoops specifically recommended for these users. urbanspec H-Series Bike Hubs can be configured to accommodate these standards, ensuring compliance while providing secure and efficient cycle storage solutions.



Sheffield Hoop Stores

Single Aisle:

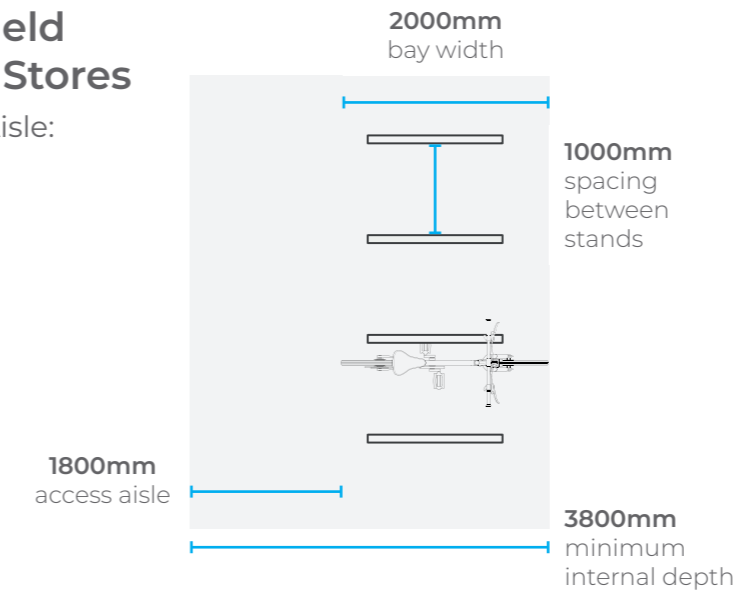

Double Aisle:

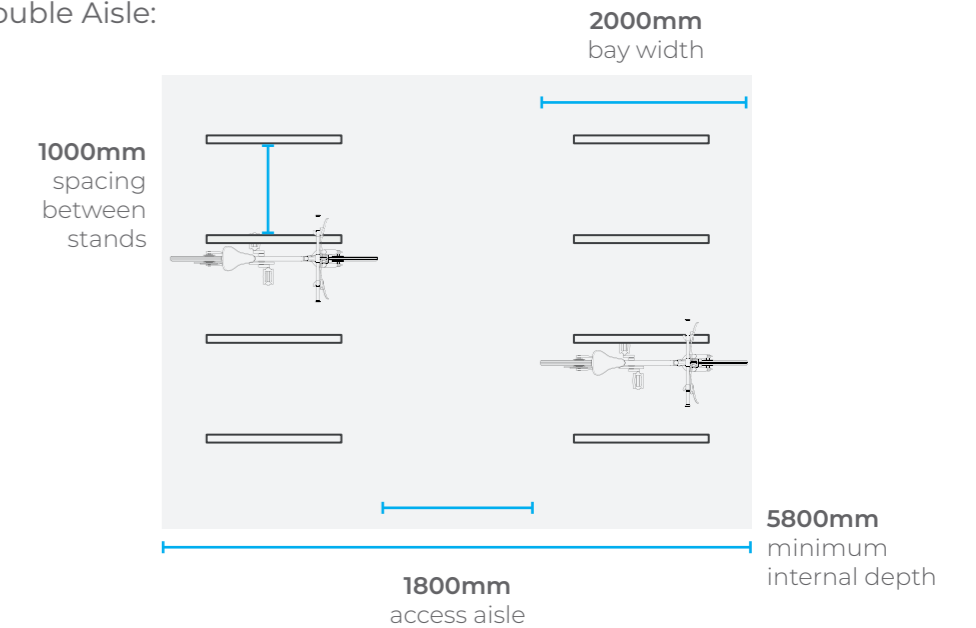

Two-Tier Rack Stores

Single Aisle:

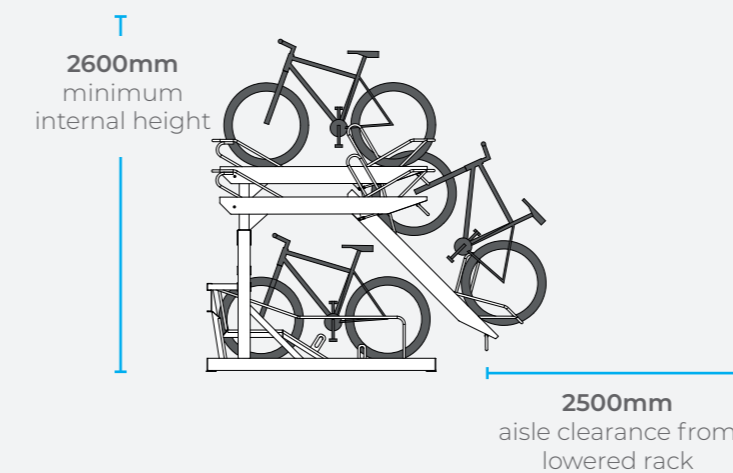

Double Aisle:

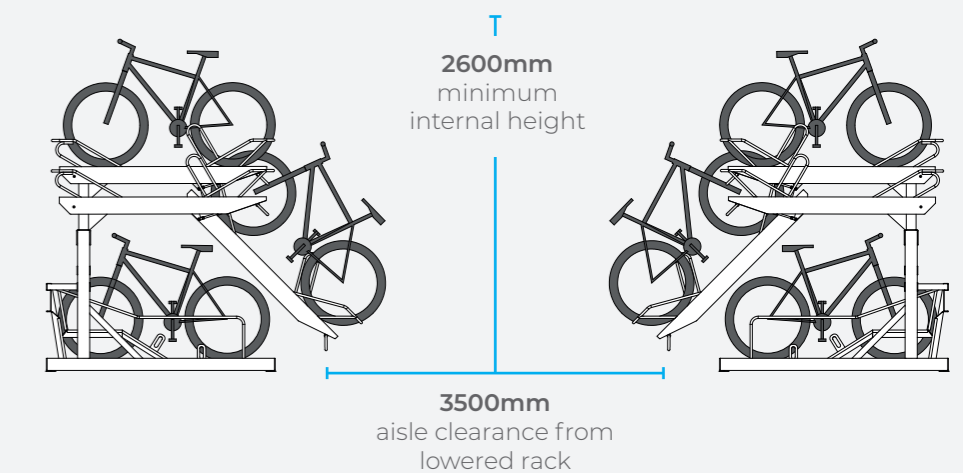

Reducing Bike Theft in Cities: The Demand for Secure Bike Storage

In London, around 50 bikes are reported stolen every day. The actual figure, taking into account incidents not reported to the police, is likely to be even higher. Close to 20,000 bikes are stolen every year in the capital, as thousands of residents continue to wait for secure bike storage.

Following on from their successful #ThisIsAwkward campaign in 2022, charity campaign group Clean Cities, working in collaboration with Stolen Ride, has called on residents in London to share their stories of bike theft and the impact this has had on them. The #StolenDreams campaign has seen 1,000 missing bike posters, known as 'lamppost laments', placed across the Capital as part of an increasing demand for secure bike storage facilities.

urbanspec takes a look at the challenges faced by city residents when there is a lack of access to secure bike storage, particularly for those living in flats and apartment buildings, and how the demand for these resources can help restrict the development of large-scale bike theft currently affecting urban cyclists.

Secure Bike Storage for City Residents

A cyclist's journey invariably begins and ends at home. For many residents in flats and apartment buildings, parking their bike at home currently means carrying it up flights of stairs or storing it inconveniently on a balcony or in communal living spaces, which

can then compromise fire safety guidelines. This is an impractical solution, and is particularly an issue for residents living in older flats or high-rise buildings, where space is at a premium.

For cycling to become a convenient, sustainable travel alternative for city residents in flats and apartment buildings, providing secure, on-street cycle parking in residential areas is crucial. It's worth noting that the provision of on-street bike parking is typically a more efficient use of limited urban space than car parking, with one parking space providing the necessary dimensions for storing several bikes, while semi-vertical and two-tier racking systems are designed specifically to maximise space in high-density settings.

A lack of secure bike parking and storage facilities, however, has ultimately allowed bike theft to develop significantly in our urban settings. For the perpetrators, bike theft presents a low-risk, high-reward crime, however, it is rarely victimless. Many city residents rely on their bikes for travel and the resulting impact of a theft can be debilitating. In cities like London and Brighton, the resulting conviction rates from these incidents are troubling.



Bike Theft Statistics

Between June 2021 and July 2022, almost 90% of bike thefts reported to the police in England and Wales were closed without a perpetrator convicted. Of the 74,421 bike thefts reported during this time period, no suspect was even identified in 66,769 of the cases.

Brighton is another city with a significant bike theft issue. No convictions were made across 2023 despite 798 bikes being reported stolen. Sussex Police were unable to find a suspect for 92% of the cases. Cycling campaign group Bricycles claim the lack of secure bike parking, particularly in the city centre, is acting as a direct deterrent to cycling uptake.

When a suspect is identified by police in the UK, prosecution is often challenging for a number of reasons, including victims not supporting the investigation or difficulties gathering evidence, such as eye witness accounts and CCTV. However, a number of the incidents have occurred in broad daylight in high traffic areas, underscoring the need for secure bike storage as a preventative solution.

The Demand for Secure Bike Storage

Utilising limited kerbside space efficiently, bike hangars have emerged in recent years as an innovative solution for residential streets, replacing a single car parking space with up to 6 bike parking spaces per hangar. In their Cycle Parking Implementation Plan, Transport for London (TfL) claimed that more than 50% of Londoners regard the lack of secure bike parking as a key deterrent to cycling, and a core aspect of their plan is to supply more cycle hangars across the Capital. Close to 1,200 units have been provided in over 25 boroughs, however, close to 9000 Londoners remain on borough waiting lists.

It's estimated that London's total bike storage provision will nearly double to 70,000 by May 2026, however, Clean Cities claim at least 35,000 residents across London's 21 boroughs are likely to remain on a waiting list by the same year. There has been suggestions of a lack of parity for residents regarding both provision and annual cost of a hangar spot. At £107.25, the cost for a space in a bike hangar is double that of the London average (£54).

Residents are advised by TfL to check their local council website to request a unit near their home. The units are installed on-street and purchased by local councils from suppliers. Evidence of demand is often required when evaluating new requests, however, there are other determining factors in play, such as the availability of suitable on-street space.



Secure Bike Storage with urbanspec

With a product line that covers bike modules, lockers, stores and hub buildings, secure bike storage solutions from urbanspec combine volume manufacture with custom build capability through an integrated design and engineering methodology.

Ideal for existing residential and new-build settings, our versatile formats for secure bike storage offer efficient footprint utilisation when available space is at a premium, enabling broad capacity opportunities for a variety of bike parking formats, all within a secure covered structure. Modularity in design offers opportunities to form a series of connected units, reducing the required footprint by enclosing only the bike rack space.

Access control options are accommodated within a high-quality steel door and frame design, enabling a uniform mode of access for residents. Central to urbanspec product design, designs can be easily configured to be Secure By Design compliant or incorporated into planning applications to achieve BREEAM performance requirements, enabling cycling facilities to be considered from the earliest stages of development.

A substantial resource and knowledge base enables urbanspec to simplify specifications, utilising CAD models, NBS specifications and datasheets available for download. Supporting CPD programmes provide clarity on the optimal approach to aspects such as security considerations and effective space planning.

Scan or click to use visit
our content hub



bit.ly/spec-hub

h-series
bike hubs

urbanspec H-Series is one of the most configurable design platforms for outdoor storage in the world, with over 120 pre-engineered build layouts. Within each build layout there are extensive options for bike storage capacity, cladding and frame finish types, access door size and locations, access control types and roof specification availability. Custom bike store dimensions and configurations from the same proven design platform are made possible with the urbanspec integrated design and engineering methodology.

External wall cladding panels are available in glass, coloured steel cassettes in plain or laser cut hole pattern design, timber slat and coated security mesh in v-form or high security twin-wire types. Frame finishes from the all-steel build follow a hot-dip galvanising process as standard with colour powder coated finishes optional.

h-series
HC21
open fronted, single row bike stand

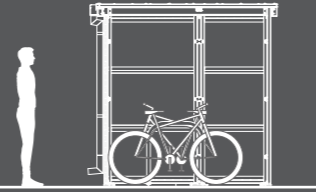

h-series
HC24
single row, semi-vertical bike rack

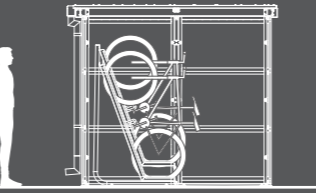

h-series
HC48
double row bike stand

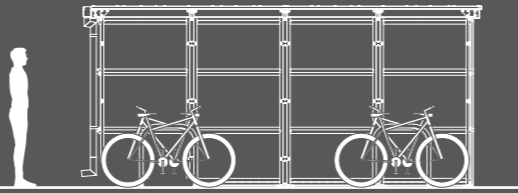

h-series
HTC60
double row two-tier bike rack

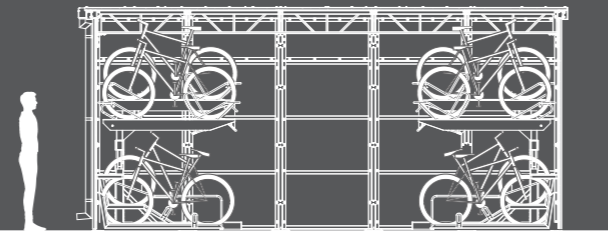

The urbanspec H-Series roof design is used throughout the bike hub range and has been developed to accommodate the structure for both extensive and intensive lightweight green roof systems with the complete system for waterproofing, water reservoir and growing medium integrated.

urbanspec integrated design and engineering for access control, extends to key operated, mechanical keypad, smartphone access and fob operated locking systems that can all be accommodated within a proven steel door and frame design. Our bike stores are available to Secured by Design specification, independently tested and certified by the Sold Secure approval body.

H-Series Bike Hub layouts are based on either a central aisle, twin-row bike rack format, or the side aisle, single row version. Both types accommodate bike stand, semi-vertical or two-tier rack types.



Space planning from the urbanspec technical team helps ensure bike storage is optimised in the available footprint, with racks and stands available for download as CAD blocks that include the required operational space, enabling areas designated for bike parking to be scoped out accurately within the design process.

m-series

bike stores

urbanspec M-Series Bike Stores are the versatile, in-line cycle storage system with efficient footprint utilisation and door access to the front of each store. There are three model depths and two model widths with extensive configurations available for frame colour, panel type, access control and integral green roof options.

At 1200mm depth, urbanspec M12 is fitted with vertical cycle racks, urbanspec M15 has a 1500mm depth and stores bike on semi-vertical racks, while the 1800mm depth model, the urbanspec M18, is fitted with Sheffield type bike stands. urbanspec MT is designed to accommodate the two-tier rack system. All variants can be specified with up to six connected modules, each with its own access door. This design reduces the required footprint by enclosing only the cycle rack space.

m-series
M12
vertical rack

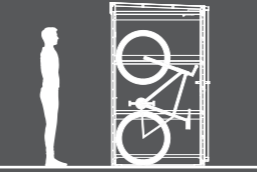

m-series
M15
semi-vertical rack

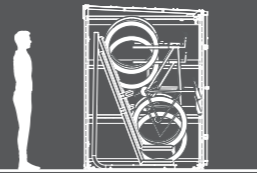

m-series
M18
bike stand

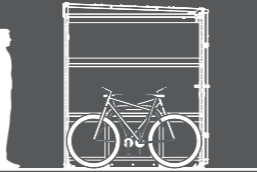

m-series
MT
two-tier rack

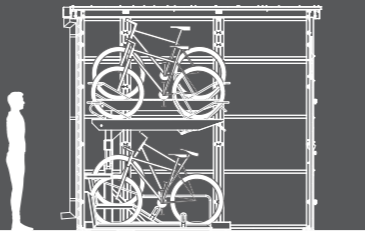

urbanspec M-Series Bike Stores are manufactured in the UK with an all-steel modular frame designed to accommodate cladding panel types in colour coated steel and timber. Frame components are finished in hot dip galvanised with colour powder coated options available. Height adjustable base plates enable effective ground fixing.

Access control options are specified from the modular lock design enabling key operated, mechanical keypad, electronic fob and smartphone activated systems to be selected. For high-security applications, urbanspec M-Series Bike Stores with Secured by Design specifications achieve Sold Secure SS104 – Gold Specification for Mechanical Security Systems for Pedal Cycles.

urbanspec M-Series Bike Store variations are available for download as CAD blocks and BIM models with NBS specifications.

Designing Effective Cycle Storage

This CPD seminar will help you understand the regulations and the science behind achieving the effective and secure storage of cycles, particularly within residential environments.

CPD Overview

- Overview of Cycling trends in the UK, and how this drives legislation and guidance for specifiers
- Define key storage types: individual or communal and internal or external, and where to use them
- Understand current legislation and guidance regarding communal store location and design
- Learn a simple 5-step process to ensure that each store is secure and fit for purpose
- Demonstrate opportunities for enhancement of biodiversity within the built environment
- Learn how to specify a storage system that caters for all users yet makes the best use of space
- Get inspiration for your next project with a broad range of class-leading case studies



Run Time

60 minutes with time allowed for questions and project advice.



Location

CPD presented in person or online using Teams, Zoom or Skype.

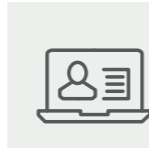

Registration

Email enquiries@urbanspec.co.uk and we will find a convenient date and time.



bike modules

BIKE-S is the secure, stylish, standalone bike storage unit with minimal visual impact on the street scene. Each low-profile module is fitted with integral wheel trays that incorporate security locking points and is customisable for finishes, graphics, door type and access control types.

Each standard module is fitted with individually lockable cycle trays, stepped to maximise space efficiency and enable the BIKE-S to store 6 bikes within the dimensions of a car parking space. Available in standard (6 bike) and quad locker (4 bike) builds, BIKE-S modules can also be connected in a series to form a larger bike parking facility.

BIKE-S bike module

1, 6, 12 or 18 cycle capacity

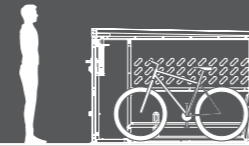

BIKE-S full height bike module

6 cycle capacity, walk-in module

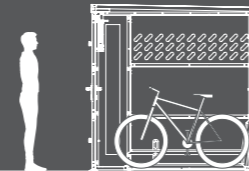

BIKE-S locker type bike module

4 individual lockable stores

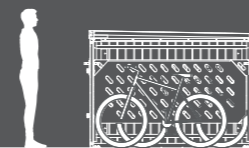

Customisable for finishes, cycle parking format and access control, the clean design aesthetic of BIKE-S communicates intent with clear cycle parking graphics, and choice of colours from SSAB Greencoat steel range with its Bio-based Technology coating. The unique slot pattern vision panels ensure clear lines of sight are maintained through the store for personal security. Plain panels can be specified as a no cost option.

Engineered for security, the BIKE-S locker module achieves Sold Secure Bronze accreditation as standard (with the exception of mechanical keypad access control version). Shielded locks, reinforced hinges and steel external panels with an innovative interlocking design that avoid the need for external fixings. All bolted internal frame and ground fixings are fitted with security fixings and welded security locking points at the front of the store makes loading and securing bikes easy.

e-bike, e-scooter storage and charging modules

urbanspec BIKE-E Storage & Charging Modules have been developed in response to the rising urban popularity of e-bikes and e-scooters, with each module providing safe, secure external storage within individually lockable storage and charging compartments.

Each Bike-E Module has secure, integral battery charging compartments for 3 e-bikes and each BIKE-ES module the same secure battery charging compartments for 6 e-scooters.

urbanspec's modular product system enables additional safe, secure storage capacity in the form of 'add-on' modules, while the BIKE-S standard bike storage module can be design coordinated with the e-bike or e-scooter version.

Bike-E e-bike storage & charging module

3 e-bike capacity

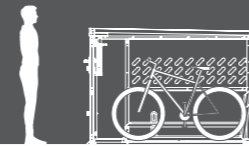

Bike-ES e-scooter storage & charging module

6 e-scooter capacity

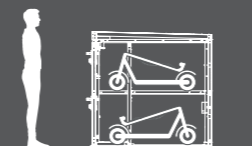

The low profile urbanspec BIKE-E design is suitable for accessible and **on-street locations**, providing **secure storage** & individual charging sockets for devices.



The low profile design is ideally suited to accessible and on-street locations, while customisable graphics and a choice of panel colours, communicate the e-bike and e-scooter storage and battery charging facilities with clarity and style. Additional specifications are available for fire-resistant enclosures, energy metering systems and access control types.

Engineered for security, urbanspec BIKE-E and BIKE-ES Storage & Charging Modules can achieve Sold Secure Bronze accreditation as standard. Shielded locks, reinforced hinges and steel external panels incorporate an innovative, interlocking design that requires no external fixings.



The all-steel build of urbanspec BIKE-E and BIKE-ES module framework has a hot dip galvanised coating as standard with colour powder coated options.

Safe Storage of E-bikes and other LEVs

You will already be accustomed to specifying cycle storage and aware of the emerging requirement to ensure that facilities can be quickly adapted for storing and charging e-bikes and other e-mobility devices or Light Electric Vehicles (LEVs).

But are you aware of your obligations when doing this? It is no longer just a question of adding an electricity supply and charging points. Following a number of fire incidents involving lithium-ion batteries, Fire & Rescue Services and Insurers are urgently issuing guidance on safe storage and charging facilities.

So get ahead of the game and book your presentation today so that you're in a position to advise clients regarding the potential risks and the solutions that can be employed to mitigate this.

CPD Overview

- Why LiB-powered e-mobility devices represent a significant fire risk
- What causes an LiB to go into thermal runaway
- What actually happens during such an event
- The frequency at which such events are occurring
- The implications for specifiers and steps to mitigate risk



Run Time

60 minutes with time allowed for questions and project advice.



Location

CPD presented in person or online using Teams, Zoom or Skype.



Registration

Email enquiries@urbanspec.co.uk and we will find a convenient date and time.



r-series, l-series

bike lockers

With clean lines, low-profile design form and customisable finishes, urbanspec Bike Lockers have been developed to provide individual external storage for up to three bikes that is both secure and easy to use. Full-width hinged or sliding doors and integrated wheel trays enable bikes to be locked securely in an upright position.

Secure external storage of bikes and household items on many residential developments is integral to the street scene and the minimalist aesthetic of urbanspec bike lockers can be specified to coordinate or contrast with elements of the built environment.

l-series
LC1
individual bike locker



r-series
RC2/3
2 or 3 cycle capacity

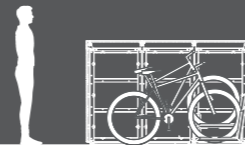

The clean lines, **low-profile design & customisable finishes** of the urbanspec Bike Locker enables design coordinated storage of bins, cycles & scooters.

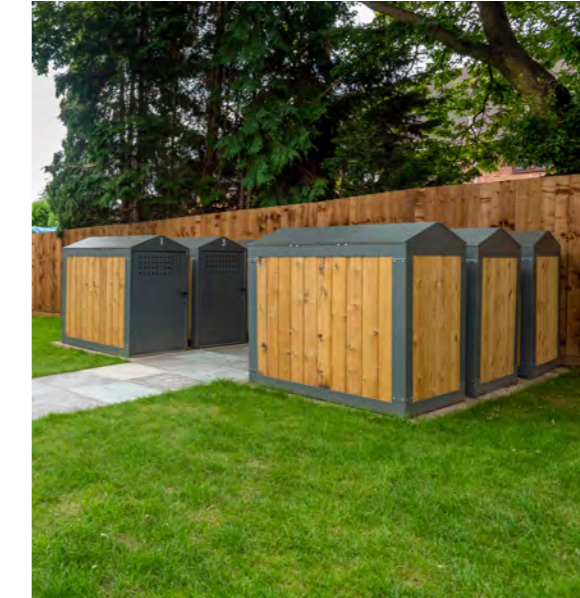

An all-steel construction combines durability and style, with side panels, roof sections and sliding door frames manufactured from colour coated steel, formed as cladding cassettes and panel fixed internally for security. urbanspec steel panel cladding can be specified with hole pattern laser cut designs, graphic wraps or timber infill panel options that can help soften the built environment. All bike lockers are shipped in panel format for site assembly, facilitating installation in locations with restricted access.



bike parking

Advanced manufacturing of high volume bike shelters and bike rack products enable short lead times, capacity format variations and competitive pricing. From vertical hanger to two-tier bike racks, all types are available from stock as standalone or pre-configured to maximise capacity in urbanspec stores and shelters.

As sustainability strategies and urban planning evolve to reduce congestion and gridlock, the need for innovative, high-quality bike parking products is increasing. Today's cyclists should have confidence that their bicycles will be safely stored during work or school.

ST

rail fix, root fix or surface fix bike stands



SV

semi vertical bike stands

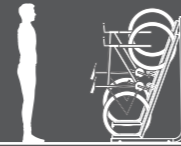

T2 two tier

manual, gas assisted or fixed bike stands

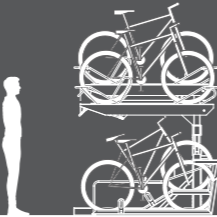

urbanspec bike stands & racks are designed for hassle free installation with **class-leading delivery times & product warranty.**



Secure and well-planned bike parking facilities encourage more people to adopt sustainable forms of transport that contribute to reduced carbon emissions while promoting health and wellbeing. Providing cyclists with a designated storage area ensures that cycles are parked in an orderly manner and not causing obstruction to site users.

Offering detailed compatibility with our bike parking products, urbanspec bike shelters are produced in semi enclosed CL format, with single row CS and double row CLS both available in single level and two-tier rack formats.

bike shelters

urbanspec bike shelters follow a consistent design theme, with the all-steel manufacture, fully-welded end frames and modular connecting sections for ease of specification, efficient shipping, hassle free installation and long service life.

Advanced manufacturing of high volume bike shelter products enable short lead times, capacity format variations and competitive pricing. urbanspec bike shelters are produced in semi enclosed CL format, with single row CS and double row CLS both available in single level and two-tier rack formats. In addition to standard product configurations, urbanspec integrated design and engineering methodology make bespoke bike shelter builds possible within proven design formats.

CL

semi enclosed single row bike shelter

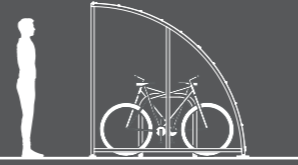

CLE

semi enclosed bike shelter compound

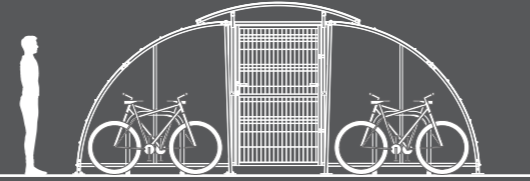

CS & CLS

single or double row bike stands

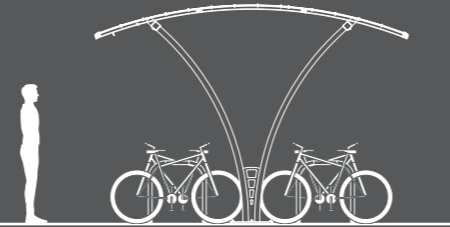

CST & CLST

single or double row two tier rack

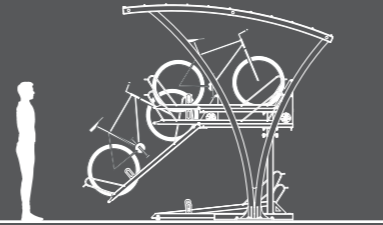

urbanspec bike shelters provide reliable, cost-effective weather protection for bikes with **single row, double row & two-tier bike rack** options available.



The advanced polycarbonate roofing and enclosure cladding systems used are highly durable, being able to withstand impact damage and discolouration from the sun's harmful UV rays.

urbanspec bike shelters are hot dip galvanised frame finish as standard for maximum durability with optional coloured powder-coated finishes available to complement existing architectural designs or meet project requirements.

From vertical hanger to two-tier racks, all bike rack types are available from stock as standalone or pre-configured to maximise capacity in urbanspec shelters.

bike storage security specification

Secured by Design (SBD) operates an accreditation scheme on behalf of the UK Police Forces for products or services that have met recognised security standards. Such products or services must be capable of deterring or preventing crime and are known as being of a 'Police Preferred Specification'.

To achieve this, products have to be either independently tested, fully certified by an independent third party or tested and certified by an approved body such as Sold Secure.

urbanspec products are tested and certified by the approved body Sold Secure. To keep the Police Preferred Specification our products are required to be regularly re-tested and we have an annual inspection by a UKAS body of our manufacturing facility to ensure quality and performance is maintained.

Sold Secure is administered by the Master Locksmiths Association. Approval is classified into 3 main categories; Bronze, Silver & Gold. The categories reflect the amount of time allocated per test and the type of tools used from a toolkit based on insurance and police information.

The higher the grading the higher the security provided and urbanspec products are tested against the criteria for SS104 Bicycles and SS314 Security Cabinets.



Sold Secure SS104 Bicycle Bronze

Sold Secure Bronze for Bicycles offers theft resistance against a basic tool list aimed at preventing opportunistic crime and to achieve this category, the storage unit components must resist a 3 minute attack with light manual tools such as small hack saws, screwdrivers, lock picks and claw hammers.

In order to achieve Sold Secure SS104 Bicycle Bronze the urbanspec BIKE-S Bike Module has the following features:

- 1 Standard production unit with addition of 3 star lock cylinder to the access door locking system



Sold Secure SS104 Bicycle Gold

Sold Secure SS104 Bicycle Gold offers the highest level of security with theft resistance against a specific tool list aimed at preventing dedicated attacks. To achieve this the unit components must successfully resist a 5 minute attack with medium-weight manual tools that include prybars, extension rods, cold chisels stillsons and sledgehammer.

urbanspec H-Series Bike Hubs and urbanspec M-Series Bike Stores specified to achieve Sold Secure SS104 Bicycle Gold include the following features:

- 1 Welded-In metal hinge shields to access door
- 2 Additional welded metal flange fitted to access door frame
- 3 Welded-In manganese steel lock cover, flange and lock keep
- 4 Welded metal anti-door removal plates to access door frame
- 5 Additional metal security bars fitted internally to access door panel
- 6 3 star lock cylinder to the access door locking system
- 7 Additional metal security bars fitted internally to each panel section

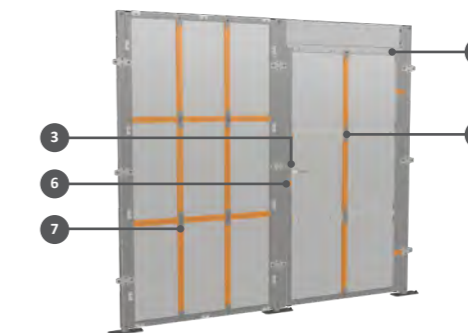

Sold Secure SS314 Cabinet Silver

Sold Secure SS314 Cabinet Silver offers theft resistance against an enhanced tool list aimed at preventing more determined attacks. To achieve this rating the unit components must prevent entry for a 5 minute attack with heavy manual and light electrical tools such as jigsaws, cordless drills and impact drivers.

urbanspec H-Series External Storage Buildings and M-Series External Stores specified to achieve Sold Secure SS314 Cabinet Silver include the following features:

- 1 Welded-In metal hinge shields to access door
- 2 Additional welded metal flange fitted to access door frame
- 3 Welded-In manganese steel lock cover, flange and lock keep
- 4 Welded metal anti-door removal plates to access door frame
- 5 Additional metal security bars fitted internally to access door panel
- 6 Steel security mesh liner panel internally to access door
- 7 3 star lock cylinder to the access door locking system
- 8 Additional metal security bars fitted internally to each panel section
- 9 Steel security mesh liner panel internally to each panel section

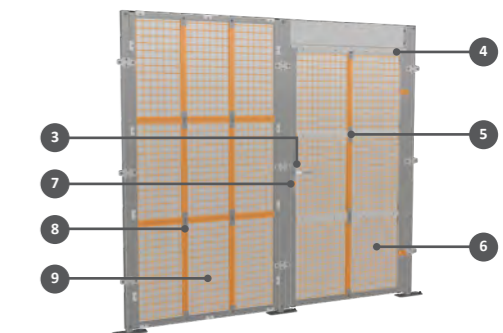

Bin stores, screens & enclosures

urbanspec offers one of the largest external waste and recycling storage product ranges in the UK, including bin store buildings, bins stores, bin lockers and bin screen systems.

Our integrated design and engineering methodology combines the efficiency of volume manufacture with custom build capability. This can include green roof applications, with external bin stores being ideally suited to the provision of valuable components in achieving Biodiversity Net Gain targets for new developments.

From B-Series and P-Series Bin Stores, R-Series Bin Lockers, H-Series Bin Store Buildings, E-Series Bin Screens Systems to S-Series Enclosed Bin Screens, urbanspec products share a unique design format that enables specifiers to select panel type and finishes with multiple options for customisation. This makes site wide design coordination and single source procurement a realistic concept for external works projects.

Our bin storage solutions are an essential tool in the management of waste-streams, helping to increase recycling success for residential and commercial applications alike while reducing associated fire risk, litter, fly-tipping and antisocial behaviour. The urbanspec integrated design and engineering approach extends to access control options for all types of bin store, where key operated, mechanical keypad, smartphone access and fob operated locking systems can be accommodated within our proven format.



Simpler Recycling – what you need to know as a specifier

The Government has finally confirmed changes to the way refuse and recycling are collected from all properties across the UK, aiming to encourage proper recycling practices. While these changes are intended to end the postcode lottery and reduce the need for multiple bins, the requirements will still vary between local authorities and be introduced at different times, depending on building types and locations – creating a potential headache for specifiers.

urbanspec is here to help you navigate the complexities, ensuring you allocate sufficient space for waste and recycling storage on your development, regardless of its location or occupancy timeline. As specific requirements are announced by each local authority, we'll guide you in determining the exact type and quantity of bins needed and, as always, help you design your storage solutions to maximise recycling rates, enhance resident satisfaction, and ensure operational efficiency.

CPD Overview

- **Government Waste Collection Changes:**
Key updates and their impact on developments
- **Navigating Local Authority Requirements:**
Understanding variations and ensuring compliance
- **Designing Efficient Waste Storage:**
Maximising space, recycling, and operational effectiveness

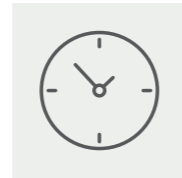

Run Time

60 minutes with time allowed for questions and project advice.



Location

CPD presented in person or online using Teams, Zoom or Skype.

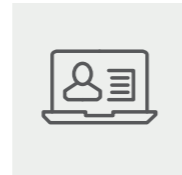

Registration

Email enquiries@urbanspec.co.uk and we will find a convenient date and time.



h-series

bin store buildings

The process of design delivery for bin store buildings can be challenging, with the potential for disconnect between design specification and realisation on site resulting in project overspend and consequent reduction in scope of works.

urbanspec H-Series Bin Store Buildings have been developed specifically to overcome these challenges and offer one of the most configurable design platforms for external storage in the world. Over 120 pre-engineered build layouts can be individually specified for storage capacity, panel cladding type, frame finishes, access door size, door location, access control type and roof type. Custom bin store dimensions and configurations from the same proven design platform are made possible with the urbanspec integrated design and engineering methodology.

**h-series
HB24**
the narrowest bin store building

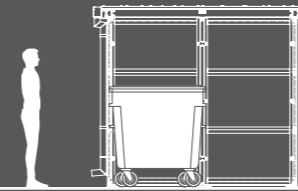

**h-series
HB48**
the largest bin store building

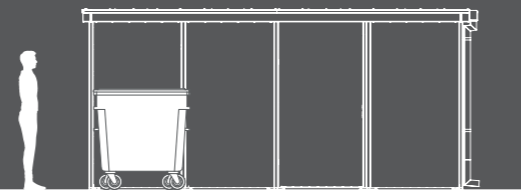

Every urbanspec product is UK manufactured in accordance with BS EN 1090, ISO9001 and ISO14001 accredited processes and our steel frame finishes can be selected as hot-dip galvanised or colour powder coated with external panel types from timber or steel including laser-cut design patterns.

The urbanspec H-Series roof design has been developed to accommodate the structure for both extensive and intensive lightweight green roof systems with the complete system for waterproofing, water reservoir and growing medium integrated.

urbanspec integrated design and engineering for access control, extends to fire-resistant wall and roof panel specifications accommodated within the proven steel door and frame design, reducing fire risk where bin store facilities cannot be located outside of the six metre recommended distance due to site constraints.



Specifying urbanspec H-Series Bin Store Buildings is made easy with clear technical product information for configurations and options, while site-wide coordination of outdoor storage units and street furniture is possible with a library of CAD models available for download.

p-series

bin stores

Enclosing wheeled bin containers and controlling user access, urbanspec P-Series Bin Stores are well established as the tough, versatile bin storage solution, effectively increasing recycling, while reducing fire risk and side waste issues.

Design configurable for bin capacity, features and finishes, urbanspec P-Series Bin Stores consolidate waste stream containers in a row of neat housings, secured at a safe distance from property and convenient for RCV access.

urbanspec P-Series bin stores are produced in two sizes with PL models housing two wheeled bins up to 240L capacity, and PM the 4-wheeled bin containers from 660L to 1280L.

p-series

PLN

enclosure for 140L capacity bins

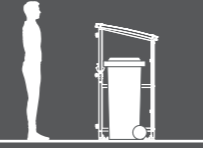

p-series

PLX

enclosure for 240L - 360L capacity bins



p-series

PMC

enclosure for 720L - 940L capacity bins

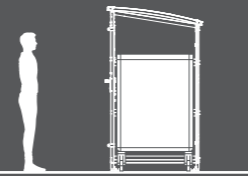

p-series

PM

enclosure for 660L - 1280L capacity bins



All P-Series bin stores control user access through a waste stream specific aperture in the front door. Integral shelving for the storage of recycling boxes and caddies within the unit is available as an option.

Reduced fire risk is central to urbanspec P-Series design and where Bin Store units cannot be located outside of the six metre recommended distance due to site constraints, the units can be specified with fire-resistant wall and roof cladding options.

The urbanspec P-Series steel frame is hot-dip galvanised as standard with colour powder coated finishes available. External panel specifications are available clad in timber or steel with optional colour schemes that enable outdoor storage units to be coordinated with architectural building fabric design.

Designing Effective Waste & Recycling Storage

This CPD seminar will help you understand the regulations and the science behind effective containment of waste and recyclable materials awaiting collection within residential environments.

CPD Overview

- Overview of Waste & Recycling in UK, how this drives legislation and guidance for specifiers
- Demonstrate key storage types: internal, external and underground, and where to use them
- Understand current legislation and guidance regarding communal store location and design
- Learn a simple 10-step process to minimise fire risk and waste costs and increase recycling
- Demonstrate opportunities for enhancement of biodiversity within the built environment
- Learn how to specify the right storage system, whether internal, external or underground
- Get inspiration for your next project with a broad range of class-leading case studies

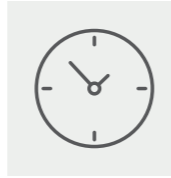

Run Time

60 minutes with time allowed for questions and project advice.



Location

CPD presented in person or online using Teams, Zoom or Skype.



Registration

Email enquiries@urbanspec.co.uk and we will find a convenient date and time.



b-series

bin stores

urbanspec B-Series define collection points for waste and recycling in the urban environment; designed to represent clean space with a minimalist style that emphasises key sustainable values.

All-steel modular construction, welded frame components, precision engineered assemblies, multistage pre-treatment and high specification colour coating process make for a reliable product system. Our manufacturers warranty backed by nationwide site engineers ensure urbanspec installations are maintained in service week for the long term.

Enclosing wheeled bin containers with waste stream specific apertures, urbanspec B-Series is manufactured in four model sizes accommodating either 2 or 4 wheeled bin containers from 240L to 1280L capacity.

b-series
B480
enclosure for 140L - 240L capacity bins

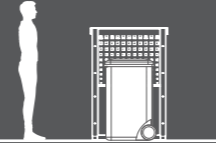

b-series
B1100
enclosure for 1100L capacity bins

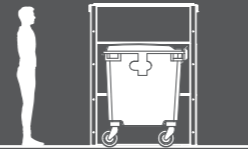

b-series
B1280
enclosure for 1280L capacity bins

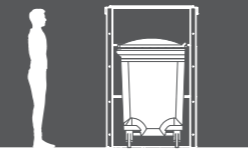

Design features unique to B-Series Bin Stores include integrated rainwater management, height adjustable base plates, a 175 degree door opening with hold back system and configurable access control options. Assisting urban design planning, B-Series can be factory specified for either front or rear bin loading and units can be added to form a series of enclosures with the ability to step each one in height enabling, sloped locations to be accommodated.

Architectural design options include integral green roof, timber slat panels, laser cut hole pattern designs in colour coated steel and vinyl wrap graphics with corporate or recycling stream colours. B-Series products are designed to maximise visual messaging opportunities that increase recycling and enhance the street scene aesthetic.

r-series

bin lockers

urbanspec R-Series Bin Storage Lockers house waste and recycling containers with the architectural style demanded by residential development frontages. With available space often at a premium, the integral sliding front door panels maintain a compact operational envelope and the low-profile design, with colour coated finishes throughout, minimises visual impact on the streetscene.

Design options include integral green roof, hinged door series, internal shelving, timber slat panels, laser cut hole pattern designs in colour coated steel and vinyl wrap graphics with corporate or recycling stream colours.

R-Series Bin Storage Lockers can be selected alongside other products in the urbanspec R-Series range for design coordinated bike and outdoor equipment storage.

r-series

RB2/3

140L - 360L 2 or 3 no. 2-wheeled bin locker



Bin Lockers can be specified alongside other urbanspec r-series products for a **coordinated look.**



All-steel construction combines durability and style with exterior panels, roof sections and door frames manufactured from colour coated steel, formed as cladding cassettes and fixed internally for security. Integral fixing points within the unit base frame enable ground anchors to be installed hidden from view.

urbanspec integrated design and engineering approach enables R-Series to be readily adaptable for bespoke applications including double stacked recycling container configurations and the supply of roof and door panel sections only for a masonry construction surround. These hybrid designs combine the benefits of proven components, materials and finishes with construction elements required for structural and ground engineering requirements.

e-series
bin screen systems

urbanspec E-Series Bin Screen Systems are the design-led visual screening solution for bin containers and fixed plant services, giving architects and specifiers the freedom to add unique style to a project. Innovations in laser-cut steel processing together with extensive manufacturing knowledge provides the freedom to recreate inspirational designs reliably and cost-effectively.

urbanspec E-Series is a bolt-down modular system that utilises a base plated column design enabling finishing groundworks to be completed in sequence without the requirement for disruptive installation of cast in foundations. Certain gate specifications, panel heights and site locations may require cast in foundations as directed by structural engineering requirements.

e-series
EL
for 140L - 240L capacity bins



e-series
EM
for 660L - 1280L capacity bins

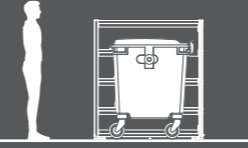

e-series
EH24
the narrowest eh design

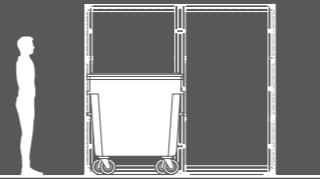

e-series
EH48
the largest eh design

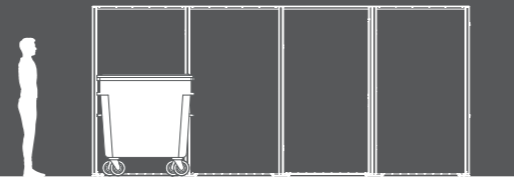

urbanspec E-Series Bin Screen Systems are the **design-led visual screening solution** for bin containers and fixed plant services.



urbanspec EL and EM models provide screening for a single row of 2 or 4 wheeled bin containers with divider frames between each and are often specified as a compound design with two units facing each other. The EH design is a complete Bin Screen Enclosure system, available from 65 pre-engineered design layouts with custom design and build options available. For all versions of E-Series Bin Screen Systems, urbanspec provides end to end project delivery from specification assistance, design approval drawings and manufacturing to delivery and installation services.

Specifying E-Series Bin Screen Systems is made easy with clear, downloadable technical information for configurations and options.

s-series

covered bin screens

urbanspec S-Series Covered Bin Screens are the premium screening solution for waste containers with interlocking cover panels to access bins for loading and removal without the need for hinged doors.

Designed for high-rise developments where views from upper floors are a particular consideration, unique self-supporting cover sections combine with the base frame and panels to fully enclose the bins. The sliding door sections use a heavy duty roller-track system on the base frame to access the waste containers. Hook-type locking systems secure the sliding door sections, restricting unauthorised access.

s-series
S2/S3

for 2 or 3 660L - 1280L capacity bins

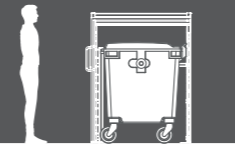

urbanspec S-Series Covered Bin Screens are the **premium screening** solution for waste containers.



S-Series covered bin screens are available in two sizes with capacity for two or three four-wheeled bins of up to 1280L capacity. Cladding systems include sustainably sourced softwood and hardwood with both vertical and horizontal fixing patterns and a variety of coloured steel cladding options.

Inspirational bin screens are made possible with custom hole pattern designs laser cut into coloured steel cladding panels, the addition of vinyl wrap graphics and further options of integral sedum green roof.

Understanding Design Principles for Bin & Bike Storage at Stage 4 & 5

This CPD seminar will help give you a detailed insight into the planning and design requirements for bin & bike storage, following an overview on the key challenges facing the industry and planning departments.

CPD Overview

- Challenges facing the industry of bin & cycle storage
- The need for a refuse collection & cycle parking strategy.
- Typical scenarios for different housing development types
- The urbanspec specification process at stage 4 and 5:
 - Capacity Requirement: What number of bins or bikes are you looking to store?
 - Footprint: What is the available space on site for the store?
 - Security: What level of security does the store need to achieve?
 - Finishes: What frame finish and cladding design type is required?
 - Roof Design: What roof type is required?



Run Time

60 minutes with time allowed for questions and project advice.



Location

CPD presented in person or online using Teams, Zoom or Skype.



Registration

Email enquiries@urbanspec.co.uk and we will find a convenient date and time.



External stores & lockers

urbanspec external stores and lockers are easy to specify product systems for keeping equipment and belongings secure in the urban environment.

Developed as an alternative modular solution to traditional purpose built storage, urbanspec H-Series External Storage Buildings, M-Series External Stores and R-Series Lockers share a unique design format that enables specifiers to select panel type and finishes with multiple options for customisation. This makes site wide design coordination and single source procurement a realistic concept for external works projects.

Our integrated design and engineering methodology combines the efficiency of volume manufacture with custom build capability. This can include green roof applications, with external stores being ideally suited to the provision of valuable components in achieving Biodiversity Net Gain targets for new developments.

Prevention of theft or damage to contents is central to urbanspec product design with specifications available from basic level to high security. urbanspec H-Series External Storage Buildings and M-Series External Stores can be factory ordered to Secure By Design specification, certified to Sold Secure S314 Silver Specification for Security Cabinets.



h-series

external storage buildings

H-Series External Storage Buildings house equipment and materials in tough, steel frame structures, configurable for footprint, layout enclosure type and access door positions. Options for architectural finishes, roof type, access control and security specifications can be specified from the same proven design platform.

urbanspec integrated design and engineering extends to security specifications accommodated within the proven steel door and frame manufacture. H-Series External Storage Buildings can be factory ordered to Secure By Design specification, certified to Sold Secure S314 Silver Specification for Security Cabinets.

h-series
HT24
the narrowest storage building

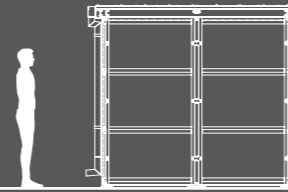

h-series
HT48
the largest storage building

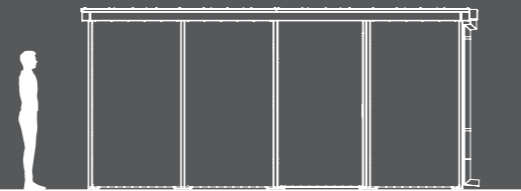

urbanspec products are UK manufactured in accordance with BS EN 1090, ISO9001 and ISO14001 accredited processes and our steel frame finishes can be selected as hot-dip galvanised or colour powder coated with external panel types from timber or steel including laser-cut design patterns.

The urbanspec H-Series roof design has been developed to accommodate the structure for both extensive and intensive lightweight green roof systems with the complete system for waterproofing, water reservoir and growing medium integrated.

Specifying urbanspec H-Series External Storage Buildings is made easy with clear technical product information for configurations and options, while site-wide coordination of outdoor storage units and street furniture is possible with a library of CAD models available for download.

m-series

external stores

urbanspec M-Series External Stores are full height, secure storage lockers with individual controlled access to each compartment. The linear design format of M-Series is ideally suited to residential schemes, optimising available footprint for multi-purpose, secure outdoor storage, including in narrow spaces close to buildings.

Designed for ease of specification, available in three unit depths and two compartment widths from standard, the class leading choice of panel types, finishes, access systems and roof options, enable M-Series products to add a welcome architectural impact to a scheme, in addition to fulfilling a practical storage function.

m-series

MT12

narrow format storage

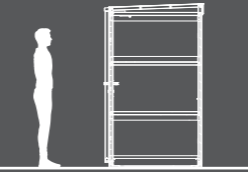

m-series

MT15

medium sized storage unit

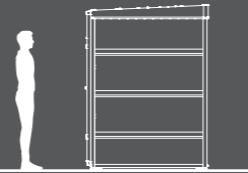

m-series

MT18

generous amount of storage including for cycles

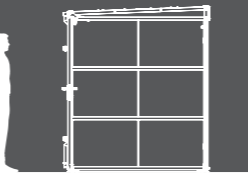

m-series

MTN18

reduced width for when space is limited

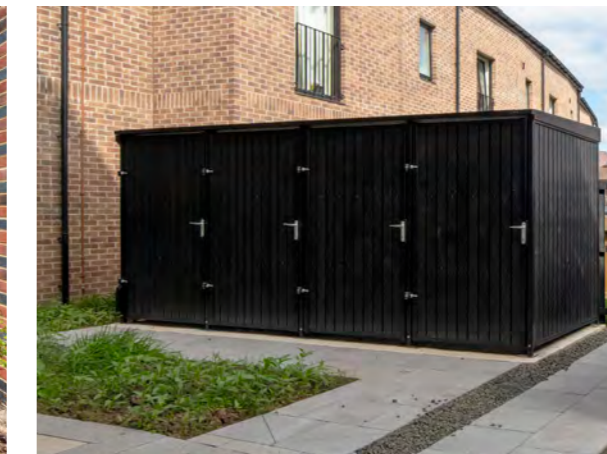
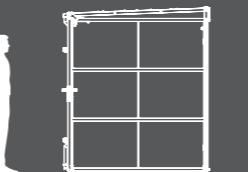

Our integrated design and engineering model extends to green roof systems, an integral means for securing Biodiversity Net Gain credentials on new developments and underscoring a commitment to championing the environment and its fragile ecosystems.

Prevention of theft or damage to contents is central to urbanspec M-Series product design with specifications available from basic level to high security. urbanspec M-Series External Stores can be factory ordered to Secure By Design specification, certified to Sold Secure S314 Silver Specification for Security Cabinets.

urbanspec M-Series structures are designed and manufactured in the UK under BS EN 9001:2015, BS EN 9001:2015 and BS EN 1090 accredited processes. Hot dip galvanised coating is standard with colour powder coat options.

Achieving Biodiversity Net Gain with External Storage

This CPD seminar will help you understand the science behind achieving Biodiversity Net Gain, why external storage presents the ideal platform for doing so, and the principles you need to follow to ensure that it is successful.

CPD Overview

- What biodiversity net gain is and why it is important
- How it is measured and what good looks like
- Which building features deliver the highest biodiversity net gain
- Why you should consider incorporating some into external storage
- Which type of greenroof to choose for your project
- What the structural and fire safety implications of a greenroof are
- How to specify for long service life with only minimal maintenance
- Examples of external storage structures with a greenroof option

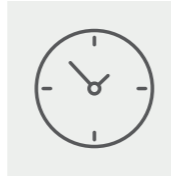

Run Time

60 minutes with time allowed for questions and project advice.



Location

CPD presented in person or online using Teams, Zoom or Skype.



Registration

Email enquiries@urbanspec.co.uk and we will find a convenient date and time.



I-series & r-series

external lockers

urbanspec L-Series and R-Series External Lockers offer versatile, compact storage in easy to specify design formats. Secure external storage of household items on many residential developments is a key element of the street scene and the low-profile design minimises visual impact.

The full-width hinged door on end-load L-Series lockers and integral sliding door panels on the side load R-Series models, reduce the operational space requirement and ensure easy access with options for locking systems. R-Series Lockers are available in two door or three door format and L-Series in standard or reduced depth.

I-series
LT12
a compact individual locker

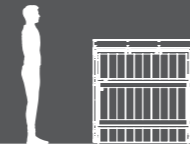

I-series
LT18
an individual locker

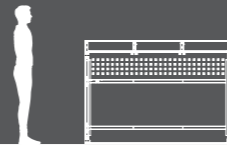

r-series
RT2/3
provides secure storage with a sleek design

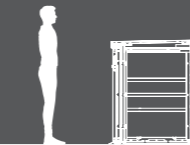

Versatile, compact storage in easy to specify formats with low-profile design to **minimise visual impact.**



An all-steel construction combines durability and style, with side panels, roof sections and sliding door frames manufactured from colour coated steel, formed as cladding cassettes and panel fixed internally for security. Integral fixing points within the unit base frame enable ground anchors to be installed hidden from view.

urbanspec steel panel cladding can be specified with hole pattern laser cut designs, graphic wraps or timber infill panel options that can help soften the built environment. Sedum green roof option on the R-Series product can be used to achieve Biodiversity Net Gain targets and create valuable pockets of biodiversity in the urban landscape.



Street furniture

City3 is a dynamic street furniture brand for the urban environment, with a design language that represents clean space and emphasises sustainable values.

City3 product scope includes litter bins, seating, benches, shelters and planters, with each design series sharing a common aesthetic form, colour scheme and finishing details. This enables architects and specifiers the freedom to be creative, while making street furniture package procurement easier for the contractor.

Manufactured in the UK from high quality, sustainably sourced materials, a steel modular construction, welded frame components, precision engineered assemblies, multistage pre-treatment and high specification colour coating process ensure a long term, reliable product system.

The urbanspec design ready process provides CAD models, technical drawings, specification references and CGI renders for download. Custom design extends the configurable process to accommodate project specific architectural features, dimensions and shapes.



city3 litter bins

City3 Litter Bins define collection points for waste and recycling in the urban environment, with the urbanspec signature design language emphasising key sustainable values.

Designed and manufactured in the UK, City3 Litter Bins are developed as product series alongside seating, benches, shelters and planters. Each City3 design series shares a common aesthetic form, colour scheme and finishing details. Litter Bins can be selected from open or semi-enclosed designs, a range of storage capacities and housing either removable steel bin liners or wheeled bin containers.

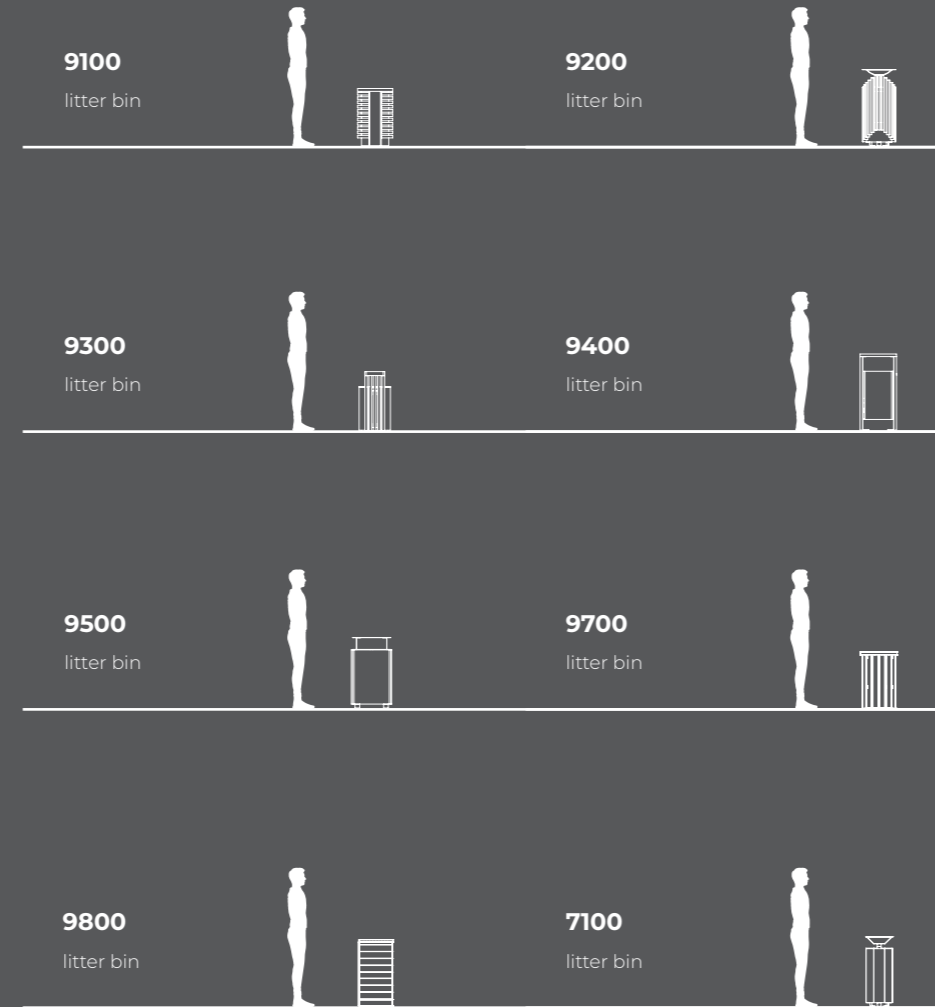

City3 Litter Bins are developed as a **product series** alongside seating, **benches**, shelters and **planters**.



All-steel modular construction, welded frame components, precision engineered assemblies, multistage pre-treatment and high specification colour coating processes ensure that City3 street furniture represents a long term investment.

city3 bollards

Bollards play a key role in the function of public open spaces, enabling pedestrian mobility and road safety in addition to specific security requirements.

City3 bollards are UK manufactured from steel and timber, developed as series design products alongside litter bins, seating, benches, shelters and planters.

Steel bollards are manufactured from mild steel with hot dip galvanised or colour powder coated finishes. Stainless steel and weathered grade steel options are available. Sustainably sourced and finished hardwood and softwoods are used for the timber bollards and timber detailing to steel hybrid models.

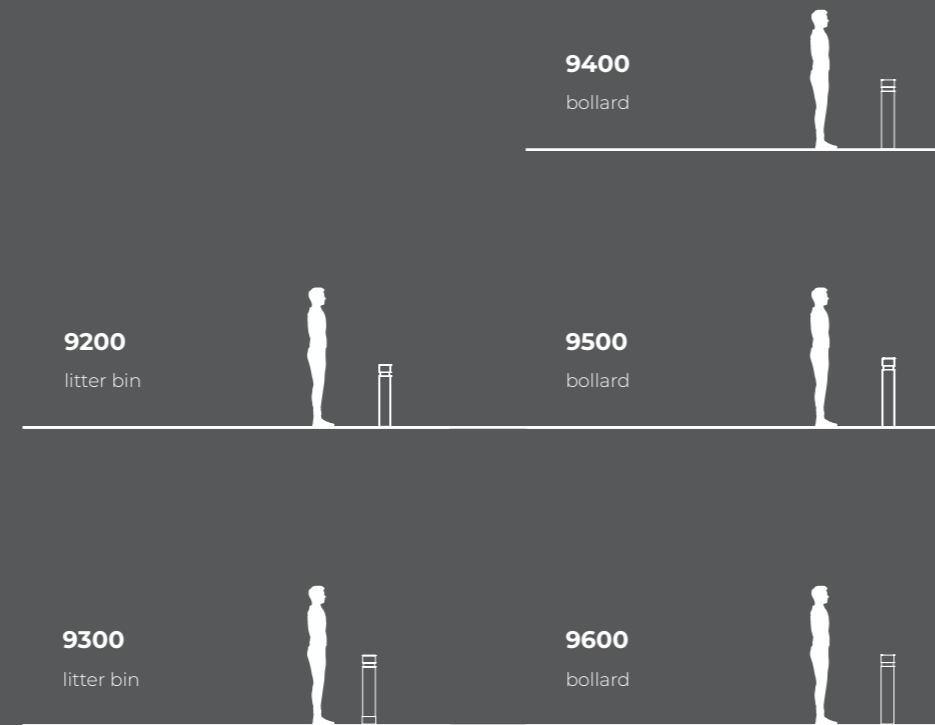

Bollards play a key role in the function of public open spaces, City3 bollards are **UK** manufactured from **steel** and **timber**.



9200 Series Bollard

A circular timber bollard with colour powder coated steel detailing.

9300 Series Bollard

The squared section version of 9200 Series with colour powder coated steel detailing.

9400 Series Bollard

A circular-section, steel security bollard available in three diameters and from stock.

9500 Series Bollard

The square section version of the steel security bollard, available in three diameters.

9600 Series Bollard

The stainless steel bollard, manufactured from circular hollow section 316 grade stainless steel with a fully welded flat top.

city3

city3 seating

City3 street and park furniture, brings series design to public seating projects in the urban environment.

Developed with a consistent, minimalist aesthetic from fully-welded steel frames, a wide choice of durable colour coatings, high quality timber detailing, City3 seating can be specified in a range of designs, in seat or bench format with options for armrests. Combined bench and table versions of certain City3 models are available for site wide design coordination of outdoor informal dining areas with the same durable style.

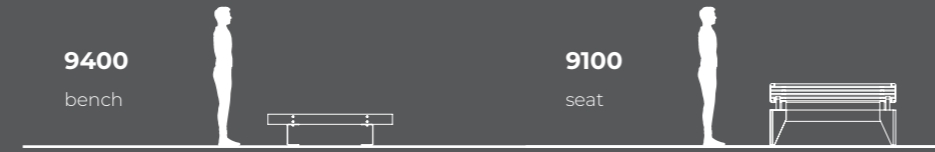

City3 street and park furniture, brings **consistent, minimalist** aesthetic series design to public seating projects in the **urban environment.**



City3 seating manufacture underscores our circular economy commitment with the use of steel as the strong and sustainable base material, produced from sustainable steelmaking processes that increase both the proportion of recycled content and use of renewable energy in production. urbanspec component specifications ensure that City3 seating units are end of service life 100% recyclable.

city3 planters

Helping define new urban space while softening the edges of the built environment, City3 planters bring the enlightening and enriching natural world closer to our everyday lives.

Developed for site wide design coordination of street furniture elements with clean, crisp lines suited to both functional projects and contemporary schemes, City3 planters are configurable for dimension, design style, timber detail and colour coated steel finishes.

UK manufactured from high quality steel and sustainably sourced timber, advanced design and production processes use off-site component manufacturing and finishing techniques with secret fix fastening systems to minimise construction assembly time and risk of handling damage in transit.



City3 planters are **configurable** for dimension, **design style, timber** detail and colour coated steel finishes.



Decorative backdrop panels can be added as screening or planting support, manufactured from steel and timber with variations that include laser cut panel designs in corten weathered grade steel or colour powder coating and log wall habitats. Integral drainage and irrigation can be specified with planter liner systems specific to the application.

city3 shelters

Throughout the urban environment, City3 shelters offer localised protection from the elements. From passenger shelters in transit terminals, parent waiting areas in schools, to payment terminals or trolley shelters in retail environments and smoking shelters in the commercial sector.

Manufactured in the UK, City3 Waiting Shelters are modular designs, easy to specify as individual or a series of connected units with the durable all-steel frame either a hot dip galvanised or colour coated finish. The radius roof design of City3 D-Series and C-Series shelters is fitted with a proven solid polycarbonate glazing system and enclosure panels also solid polycarbonate with a toughened glass options available on certain models.

d-series
Shelter
the economy level shelter

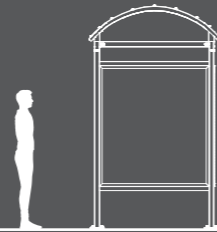

c-series
Shelter
flexible shelter system



h-series
Shelter
the highly customisable shelter

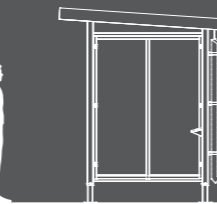

Manufactured in the UK, City3 Waiting Shelters are **modular designs**, easy to specify as **individual** or **a series** of connected units.



City3 H-Series shelters are designed with a monopitch form, steel clad roof as standard, with colour coated steel finishes and architectural enclosure options in timber slat or toughened glass. H-Series roof design can be specified with extensive or intensive green roof systems.

D-Series Shelter
The economy level shelter, D-Series comprises an all steel frame and is available in modules of 2.5m length at a standard 1.5m width.

C-Series Shelter
A flexible shelter system with a standard 2.0m width and 2.5m length module that can be specified as a single unit or a configuration.

H-Series Shelter
H-Series Shelters are a highly customisable product, designed around an innovative all-steel mono pitch roof frame.

Canopy structures

Outdoor canopies are versatile structures, providing architecturally designed covered space for building entrances, covered walkways, transit shelters, cycle parking, seating areas and many more applications.

Covered walkways serve a dual purpose, protecting site users from adverse weather conditions while providing clearly defined access routes to connect buildings. Entrance canopies can provide an inspiring focal point for a building, highlighting the entrance for visitors and creating a great first impression.

urbanspec canopies can be found on design and construction projects across the education, commercial, retail, leisure and healthcare sectors, where our integrated design and engineering methodology ensure urbanspec canopy structures bring a sense of place to the development, along with the functional requirement of shelter from the elements.

A wealth of knowledge and experience in canopy design from steel, engineered timber, tensile membrane fabric, glass and polycarbonate enables our team to develop feature structures that add architectural style to function. A wide choice of colour finishes is available for urbanspec structure framework, rainwater goods and glazing systems with advanced pre-treatment and coating processes ensuring long term durability.



urbanspec process makes it easy to specify canopy structures with the availability of online resources to assist in product selection, detail specification and technical design information. Canopy structures can be developed as either standalone or building supported, with tensile membrane fabric or solid roof cover systems.

A multidisciplinary approach delivers urbanspec canopy projects from design and manufacture to specialist delivery and installation. Within our Streetspace Structures specialist division we have the capability to deliver large scale design and build projects covering hundreds of square metres.

tensile membrane canopies

The freeform shape of tensile fabric structures results from characteristics unique to membrane tension and within established design parameters for wind loading, snow loading and rainwater management, distinctively styled canopy projects can be delivered cost effectively. These advanced fabrics have a lifespan equal to alternative covering materials and with careful design can blend successfully into both traditional and modern architectural environments.

A particular advantage of the tensile membrane design is that irregular shaped canopy footprints can be accommodated. This enables corners and custom layouts, provided that the required tension can be achieved within the design.

Shield

An innovative cantilever design

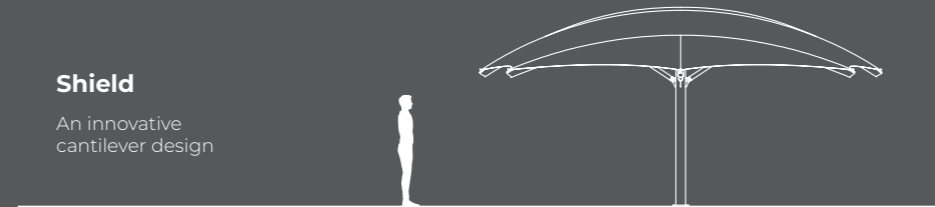

Barrel Vault Tensile

spacious with a high centre line

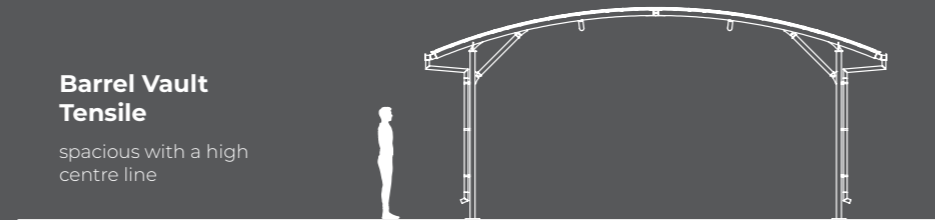

In daylight, fabric membrane translucency provides diffused, naturally lit spaces, while at night, artificial lighting can be used to create an ambient exterior luminescence. The lightweight nature of tensile membrane design typically requires less structural steel than solid roof coverings, enabling clear spans of column-free space.

The type of tensile membrane canopy selected will determine whether it can be specified as a single structure only or as a series for longer length covered space. Barrel Vault canopies are designed as linear arranged bays meaning flexibility on canopy length is achievable for such applications as covered walkways. The Hypar, Conic, Star and Shield canopies are individual structures that can be grouped together to create striking design themes.

Shield Tensile Membrane Canopies

An innovative cantilever design with a curved central spine in profile, Shield creates a distinctive aesthetic feature for both contemporary and traditional settings.



The consistent eaves height offers excellent weather protection and even shading under the structure. Low-profile, central support column layout of Shield can be engineered for cover widths of up to 10m and cover lengths up to 30m.

Barrel Vault Tensile Membrane Canopies

The barrel vault form is highly versatile, providing opportunities to create statement canopies and covered walkways without sacrificing practicality.

The portal frame structure is capable of achieving both linear bay length and clear span widths from 2m to 15m in typical design configurations. Structural frame from steel or engineered timber including hybrid designs. Eaves construction as cable edge or fixed with rainwater systems. The one-piece architectural fabric cover system will be white in colour or a close shade.

Star Tensile Membrane Canopies

An innovative twist on the classic architectural tensile form with the single central support column reducing obstructions to the covered space.

Star Tensile Membrane Canopies are specified for informal shelter where a striking architectural feature is desired and the cantilever design can be arranged in a group of canopies with alternate cover levels for stunning effect. Waterproof PVC membranes are used over a steel frame with structural designs spanning up to 7m across.

Conic Tensile Membrane Canopies

Conic tensile membrane structures create instant impact with the striking peaked form that can be specified in single, double or triple conic formats.

The central support column version has the attractive cable edge design to the tensile membrane cover while the external frame version has a fixed edge design

Conic Tensile

an instant impact with minimal support columns

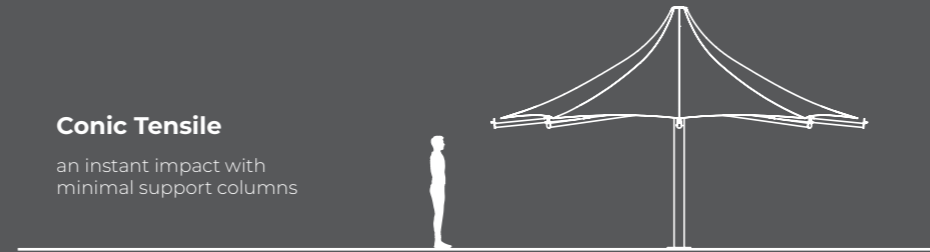

Hypar Tensile

striking looks with a good balance of shade and shelter

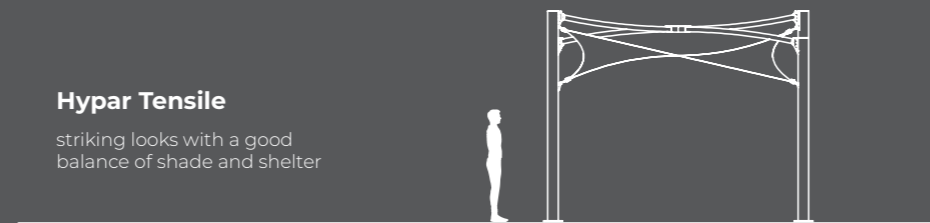

Star Tensile

an innovative twist on the classic architectural tensile form

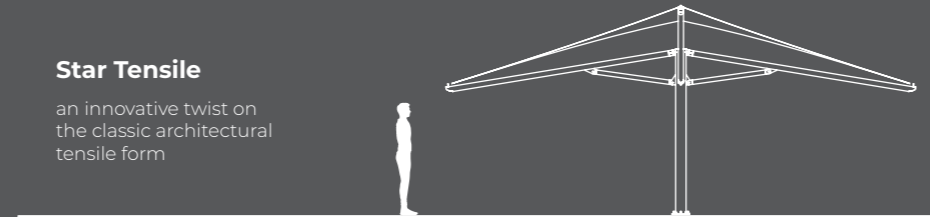

with integral rainwater systems that can be combined to cover large spaces in a series. Waterproof PVC tensile membrane over a steel frame covering from 4m to 8m as a single structure.

Hypar Tensile Membrane Canopies

The classic architectural membrane canopy design utilises a hyperbolic paraboloid form with opposing tension forces keeping the membrane tight across the span.

Selected for informal cover or shade protection with architectural value. Available as single hypar or a series design with shared tension columns. Steel frame design and waterproof PVC architectural fabric in a choice of primary colours.



solid roof canopies

urbanspec solid roof canopies are versatile structures, easily specified for layout, column spacing, roof span and rainwater management. Options include glazing type, structure finishes and enclosure elements.

With the roof form either mono-pitch or radius and cantilever or free-standing column support, solid-roof canopies and walkways provide weather-protection without compromising the design of the existing buildings.

urbanspec design and engineering capability reduces risks for specifiers and contractors, with scope for additional canopy elements such as glass enclosure panels to be integrated within the same works package.

Triton Monopitch Form

the cost-effective option

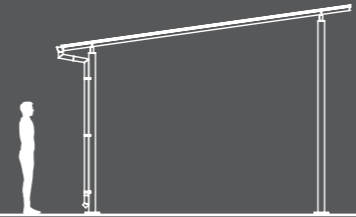

Triton Radius Form

the ultimate versatility for steel frame canopies



urbanspec design and engineering capability **reduces risks** for **specifiers** and **contractors**.



All urbanspec solid roof canopies are engineered and manufactured in accordance with BS EN 1090 EXC 2 accreditation. Designed for outstanding durability with steel and hybrid engineered timber structural elements. Cover systems in toughened glass or multiwall polycarbonate roof panels use proven aluminium glazing systems with galvanised steel rainwater goods, ensuring reliable and easy to maintain cover for the long term.

streetspace structures

A specialist division, Streetspace Structures works with clients across education, sport and leisure sectors with our Discover, Design, Construct methodology, delivering major projects on time with compliance and cost certainty at each stage.

With the knowledge and experience of structural design and compliance, the capability to deliver end to end fabrication and construction services, Streetspace Structures develop creative solutions for outdoor covered space providing inspirational shade and shelter for generations to come.



Designing Effective Covered Environments

This free CPD seminar will help you understand the regulations and the science behind effective design of canopy structures, particularly within education and sport environments.

CPD Overview

- Overview of education and sport sectors in the UK, and how this is driving some of the emerging trends in building design
- Identify the opportunities and benefits of using covered outdoor environments as opposed to traditional methods of construction
- Understand the current Building Regulations and EN Structural Standards that relate to design of canopy structures
- Learn a simple 5-step process to ensure that each structure is fit for purpose – cost-effective, aesthetically pleasing, durable and requiring low-maintenance
- Get inspiration for your next project with a broad range of class-leading case studies



Run Time

60 minutes with time allowed for questions and project advice.



Location

CPD presented in person or online using Teams, Zoom or Skype.



Registration

Email enquiries@urbanspec.co.uk and we will find a convenient date and time.



canopy specification: multiwall polycarbonate glazing

UV Protection & Weatherability

- UV Longlife protection barrier filters out over 98% of harmful UV radiation protecting the people underneath the sheet from the sun
- UV Longlife protection barrier protects the sheets from weathering and yellowing under the sun and prolongs the life of the sheet
- Marlon ST Longlife has a broad temperature range and will maintain its properties even in extreme weather conditions

Product Features

Double Sided UV

Marlon ST is available with double sided Longlife UV protection for applications in which both sides of the sheet will be exposed.

Anti-Drip

The specially designed anti-drip surface layer prevents the formation of water droplets in high humidity environments. This innovative technology can be applied to Marlon ST Longlife sheets to maintain high levels of light transmission.

Fire Performance

Marlon polycarbonate meets the highest classification of European testing (EN13501) and in the event of a fire it will soften and open, allowing smoke, heat and gases produced by the fire to escape. This 'venting' property means that damage within buildings can be limited. For more details on fire ratings please contact our technical department.

canopy specification: pvc architectural membrane

FTO SERIES Architectural PVC for ORION Fabric Canopies

PVC architectural fabrics are designed and manufactured to provide outstanding performance as a fully waterproof canopy cover. The weathering resistance of these fabrics is second to none and specialist PVDF coatings provide a super smooth finish, eliminating the opportunity for dirt to become ingrained in the fabric and spoil the appearance.

Fire retardant properties provide compliance with internationally recognised fire resistance standards. Advanced pigment technology ensures the bright colour will be maintained for many years and anti-wick treatment prevents capillary action from drawing unwanted moisture and associated stains into the base cloth. Exceptional dimensional stability prevents deformation and sagging in the membrane, and eliminates the need for re-tensioning with the passage of time. Glare is reduced while still allowing excellent light transmission with a UV blocker incorporated into the fabric.

Membrane Composition of FTO SERIES Architectural PVC

The composition details of our Architectural Structure Fabrics deliver many benefits to covered space professionals worldwide. Where standard PVC layers can attract dirt, FTO SERIES fabric has a special PVDF lacquer layer on top, which prevents dirt adhesion. This enables the structure to remain attractive for much longer periods of time, and has added benefit in reducing the level of maintenance required to keep the structure clean.

- PVDF lacquer layer for excellent weather and chemical resistance
- Acrylic lacquer layer
- PVC layer, extra smooth and flat surface with fire retardant, mildew, fungus UV and weathering resistance
- Polyester woven scrim for strength and stability. Antiwick treated. 570-620 gsm EN ISO 2286-2

urbanspec specifier process

The go-to resource for specifying external bin and bike stores, urbanspec products are designed for ease of specification, configurable to meet individual requirements and with CAD models available for immediate download.

Following urbanspec's 5-step specifier process, we establish the use type, storage capacity need, space available and build specifications for each store:

Step 1. Capacity Requirement What number of bins or bikes are you looking to store?

Step 2. Footprint Available What is the available space on site for the store?

Step 3. Security Level What level of security does the store need to achieve?

Step 4. Specifying Finishes What frame finish and cladding design type is required?

Step 5. Roof Design What roof type is required?

The output CAD Model and Specification References can then be inserted directly into project drawings, saving development time with confidence in a proven design platform.

With over 65 pre-engineered urbanspec building layouts, most external store applications can be accommodated within design variations. Bespoke design capability addresses the requirements of specific architectural design elements, planning conditions or site footprint constraints.



1. Capacity Requirement

What number of bins or bikes are you looking to store?

The number of bikes to be stored will usually be specified at planning stage but the information on waste and recycling bin volumes can be less straightforward to establish. The urbanspec team assists with the process of finding out capacity requirements, bringing specialist industry knowledge and experience in the application of planning guidance for local authorities throughout the UK.

Output from Step 1:

- Number of bikes to be stored
- Number or volume of waste and recycling storage containers to be stored

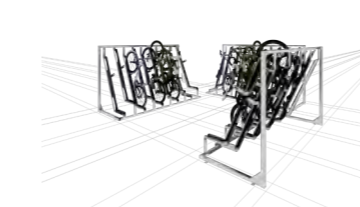

2. Dimensions Available

What is the available space on site for the store?

Once the required capacity for each store has been established, we can identify the standard or a bespoke urbanspec model that can accommodate this within the available footprint on site.

Site specific dimensions are added to urbanspec's building design platform with its pre-engineered store layouts and modular components. Space planning assists with waste and recycling container requirements while urbanspec bike hub are configured with single or double rows of bike racks that include two tiered rack options.

Output from Step 2:

- urbanspec Storage Unit Model identified that can accommodate the number of bikes or bins established in Step 1
- Type of bike rack to fit the storage unit model identified (bikes only)

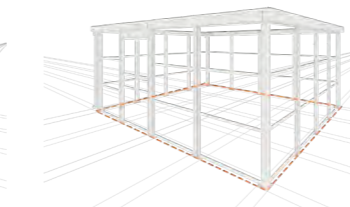

3. Security Level

What level of security does the store need to achieve?

While security ratings are more relevant to bike storage and generally specified at project planning stage, there will often be access control requirements specific to the ongoing usage of the store.

urbanspec bike hub are available to Secured by Design specification, independently tested and certified by the Sold Secure approval body. Sold Secure is classified to Bronze, Silver or Gold levels with each category reflecting a combination of time allocated for the test and the extent of the toolkit used to attempt unauthorised access to the unit.

Output from Step 3:

- Security rating for Sold Secure Bronze, Silver, Gold identified
- Access control type identified

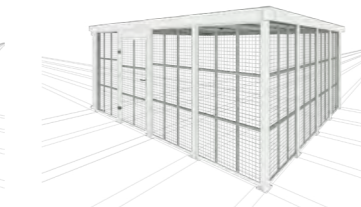

4. Specifying Finishes

What frame finish and panel cladding design type is required?

Select from a wide range of panel cladding design types compatible with urbanspec bin and bike stores to coordinate with architectural styles and deliver uniformity of design across the project.

Panel types include galvanised or colour powder coated steel, laser cut patterns in steel and a range of timber slat types. Fire retardant liner systems are available with certain cladding types. The unit steel frame and eaves detail manufactured in mild steel can be specified as HD Galvanised or Colour Powder Coated finish.

Output from Step 4:

- Frame finishes specified as HD Galvanised or Colour Powder Coated steel
- Panel cladding design type specified



5. Roof Design

What roof type is required?

Roof design specification for external bin or bike stores will be determined by a number of factors including site security requirements, planning conditions and biodiversity net gain considerations.

In standard configuration, urbanspec external stores have a profiled steel roofing system and an enclosure only specification is available where site conditions do not require a roof covering. urbanspec green roof is a lightweight system integral to the building design and available in sedum only or sedum and wildflower specification.

Output from Step 5:

- Enclosure only, steel profile roof or green roof specification selected
- Fire resistant requirements identified

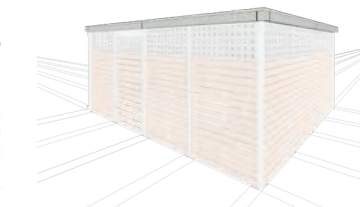

Our Brands

Streetspace Group delivers specialist design, manufacturing and construction services across a range of market sectors; from design build construction projects for sport, learning and play, to modular cycle parking, street furniture and zero-waste storage infrastructure.

Our structures business operates primarily in the education sector, starting with canopies, progressing to enclosed structures for greater weather protection, to year-round, energy-efficient building construction. ZONE Design. Build is our construction platform, providing a unique methodology in the industry, creating additional classrooms, changing rooms, offices, reception areas either as extensions or standalone buildings.

With over 20,000 units in service across the UK and North America, metroSTOR works with city authorities, housing providers and waste management organisations, providing product solutions designed to make municipal waste management and recycling easier while reducing fire risk, improving accessibility and enhancing the street scene.

urbanspec is the specification sales brand, with an integrated design and engineering methodology that delivers class leading product systems for bike parking, bin stores, canopies and street furniture.

Streetspace Group Head Office is located in Hythe, Kent, with UK offices in Hull, East Yorkshire and metroSTOR Inc offices in Connecticut, USA and Manitoba, Canada.



urbanspec is the external works brand from Streetspace, with an integrated design and engineering methodology that delivers class leading product systems for bike parking, bin stores, canopies and street furniture.

Easing the journey through specification, design and engineering, to manufacture, installation and aftercare, urbanspec product systems reduce design time, de-risk specifications and remove hassle on site for architects and contractors alike.

www.urbanspec.co.uk



Accelerating the shift towards sustainable communities, our product systems deliver on the metroSTOR Safer Neighbourhoods, Cleaner World methodology; reducing fire risk and waste costs, while improving local environments and helping deliver sustainability targets.

Developed to withstand the rigours of the urban street scene, over 20,000 metroSTOR external storage units have been installed over the past decade across the UK and USA, earning a reputation for rock-solid durability and proven effectiveness.

www.metrostor.uk



Creating all-weather sport, learning and social environments for generations, Streetspace Structures is the name for large scale, architectural covered space. We have the design technology and engineering expertise that brings creative vision to life in steel, engineered timber, glass, fabric membranes and advanced multiwall plastics.

From energy efficient glazed buildings as dining and social space, stunning wide span tensile membrane structures for sport, biodiverse green roof shelters to everyday canopies and walkways providing shelter from the elements, we demonstrate proven project solutions.

www.streetspacestructures.co.uk



We plan, design, and build modern facilities for the education sector, tailored for dining halls, social space, classrooms, special needs and offices.

Our integrated project delivery model provides seamless coordination between stages from consultancy to construction with an in-house specialist team, delivering faster projects for less cost.

www.zonedesignbuild.co.uk

enquiries@urbanspec.co.uk

0800 102 6368

www.urbanspec.co.uk

urbanspec is a brand of Streetspace Ltd, Lympne Industrial Park, Otterpool Lane, Hythe, Kent CT21 4LR

STREETSPACE LIMITED, Registered in England and Wales: 10175199. The content of this document is for your general information and use only. The colours and finishes depicted in this brochure are representations and should not be taken as accurate. Specifications are subject to change without notice. Content and specifications correct at time of print February 2025.